

8. Diagnostics Chart with Trouble Code

A: LIST OF TROUBLE CODE

Trouble code	Contents of diagnosis		Ref. to
11	Start code ● Trouble code is shown after start code. ● Only start code is shown in normal condition.		—
21	Abnormal ABS sensor (Open circuit or input voltage too high)	Front right ABS sensor	4-4c [T8B0]
23		Front left ABS sensor	
25		Rear right ABS sensor	
27		Rear left ABS sensor	
22	Abnormal ABS sensor (Abnormal ABS sensor signal)	Front right ABS sensor	4-4c [T8C0]
24		Front left ABS sensor	
26		Rear right ABS sensor	
28		Rear left ABS sensor	
29		Any one of four	4-4c [T8D0]
31	Abnormal solenoid valve circuit(s) in hydraulic unit	Front right inlet valve	4-4c [T8E0]
32		Front right outlet valve	4-4c [T8F0]
33		Front left inlet valve	4-4c [T8E0]
34		Front left outlet valve	4-4c [T8F0]
35		Rear right inlet valve	4-4c [T8E0]
36		Rear right outlet valve	4-4c [T8F0]
37		Rear left inlet valve	4-4c [T8E0]
38		Rear left outlet valve	4-4c [T8F0]
41	Abnormal ABS control module		4-4c [T8G0]
42	Source voltage is low.		4-4c [T8H0]
44	A combination of AT control abnormalities		4-4c [T8I0]
46	Abnormal G sensor power supply voltage		4-4c [T8J0]
51	Abnormal valve relay		4-4c [T8K0]
52	Abnormal motor and/or motor relay		4-4c [T8L0]
54	Abnormal stop light switch		4-4c [T8M0]
56	Abnormal G sensor output voltage		4-4c [T8N0]

**B: TROUBLE CODE 21 (FRONT RH)
TROUBLE CODE 23 (FRONT LH)
TROUBLE CODE 25 (REAR RH)
TROUBLE CODE 27 (REAR LH)
— ABNORMAL ABS SENSOR (OPEN CIRCUIT
OR INPUT VOLTAGE TOO HIGH) —**

DIAGNOSIS:

- Faulty ABS sensor (Broken wire, input voltage too high)
- Faulty harness connector

TROUBLE SYMPTOM:

- ABS does not operate.

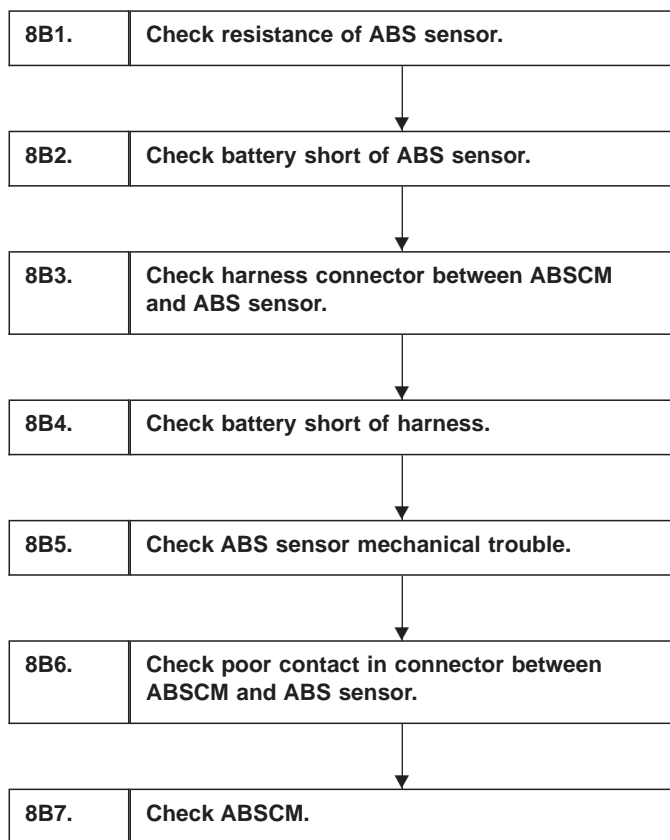

WIRING DIAGRAM:

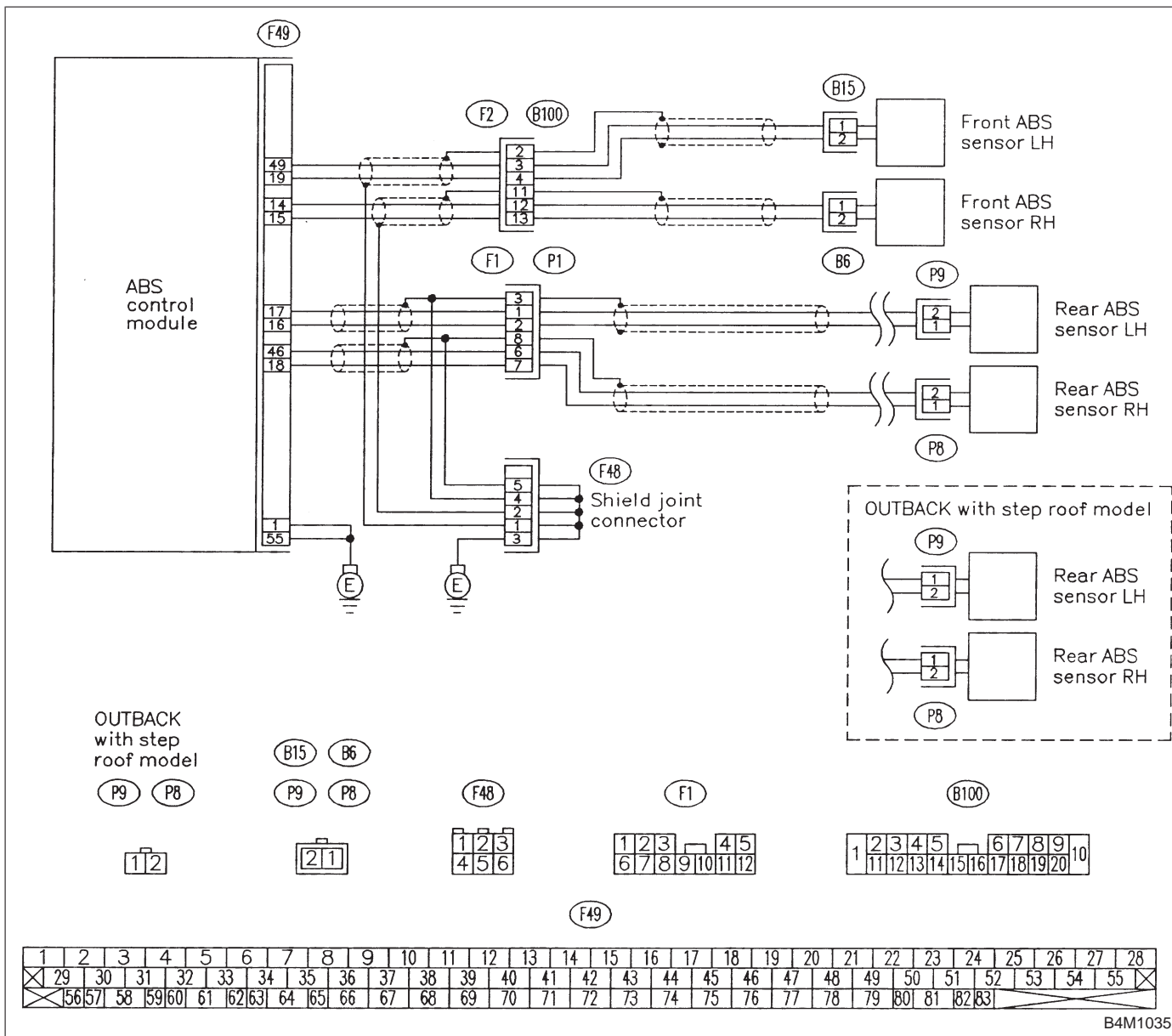

B4M1035

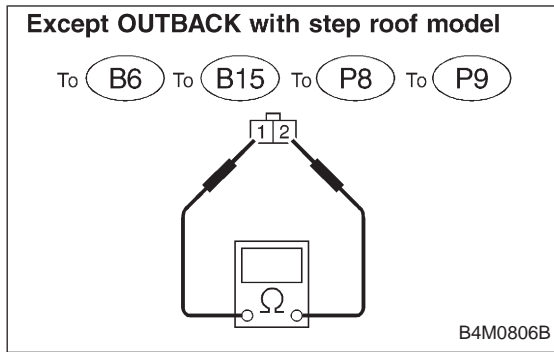

8B1 CHECK RESISTANCE OF ABS SENSOR.

- 1) Turn ignition switch to OFF.
- 2) Disconnect connector from ABS sensor.
- 3) Measure resistance of ABS sensor connector terminals.

CHECK : *Trouble code/Connector & terminal*
 21/to (B6) No. 1 — No. 2
 23/to (B15) No. 1 — No. 2
 25/to (P8) No. 1 — No. 2
 27/to (P9) No. 1 — No. 2
Is resistance 0.8 — 1.2 kΩ?

YES : Go to step 8B2.

NO : Replace ABS sensor.

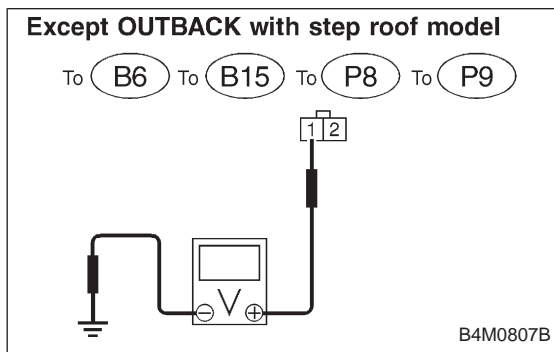
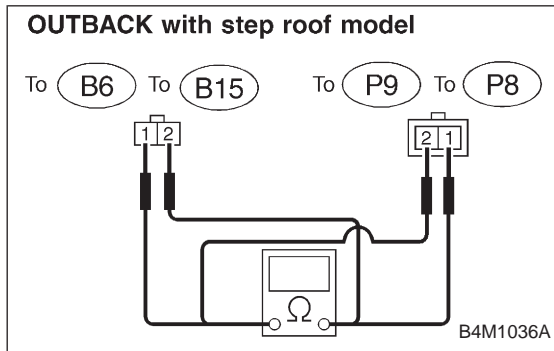

8B2 CHECK BATTERY SHORT OF ABS SENSOR.

- 1) Disconnect connector from ABSCM.
- 2) Turn ignition switch to ON.
- 3) Measure voltage between ABS sensor and chassis ground.

CHECK : *Trouble code/Connector & terminal*
 21/to (B6) No. 1 (+) — Chassis ground (-)
 23/to (B15) No. 1 (+) — Chassis ground (-)
 25/to (P8) No. 1 (+) — Chassis ground (-)
 27/to (P9) No. 1 (+) — Chassis ground (-)
Is voltage 0 V?

YES : Go to next step.

NO : Replace ABS sensor.

- 4) Turn ignition switch to OFF.
- 5) Measure voltage between ABS sensor and chassis ground.

CHECK : *Trouble code/Connector & terminal*
 21/to (B6) No. 1 (+) — Chassis ground (-)
 23/to (B15) No. 1 (+) — Chassis ground (-)
 25/to (P8) No. 1 (+) — Chassis ground (-)
 27/to (P9) No. 1 (+) — Chassis ground (-)
Is voltage 0 V?

YES : Go to step 8B3.

NO : Replace ABS sensor.

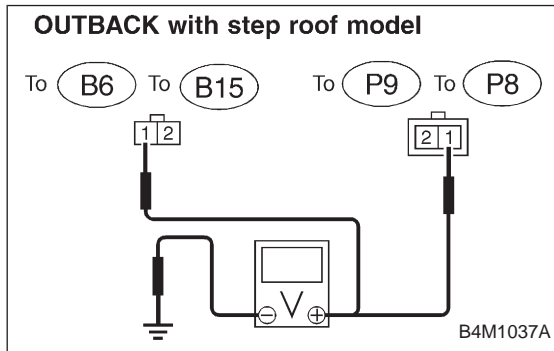

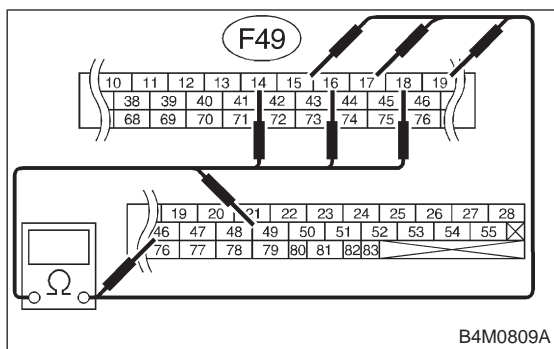
**8B3****CHECK HARNESS CONNECTOR BETWEEN ABSCM AND ABS SENSOR.**

- 1) Connect connector to ABS sensor.
- 2) Measure resistance between ABSCM connector terminals.

CHECK : *Trouble code/Connector & terminal*
21/(F49) No. 14 — No. 15
23/(F49) No. 49 — No. 19
25/(F49) No. 18 — No. 46
27/(F49) No. 16 — No. 17
Is resistance 0.8 — 1.2 kΩ?

YES : Go to step **8B4**.

NO : Repair harness connector between ABSCM and ABS sensor.

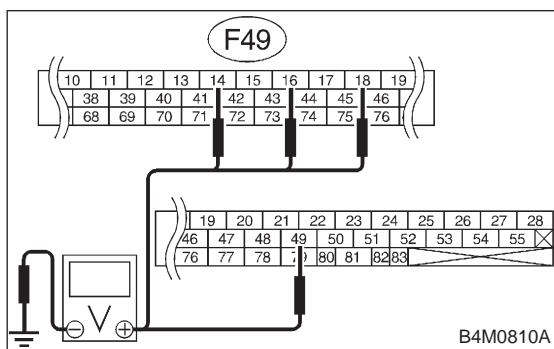
**8B4****CHECK BATTERY SHORT OF HARNESS.**

- 1) Turn ignition switch to ON.
- 2) Measure voltage between ABSCM connector and chassis ground.

CHECK : *Trouble code/Connector & terminal*
21/(F49) No. 14 (+) — Chassis ground (-)
23/(F49) No. 49 (+) — Chassis ground (-)
25/(F49) No. 18 (+) — Chassis ground (-)
27/(F49) No. 16 (+) — Chassis ground (-)
Is voltage 0 V?

YES : Go to next step.

NO : Repair harness between ABSCM and ABS sensor.

- 3) Turn ignition switch to OFF.

- 4) Measure voltage between ABSCM connector and chassis ground.

CHECK : *Trouble code/Connector & terminal*
21/(F49) No. 14 (+) — Chassis ground (-)
23/(F49) No. 49 (+) — Chassis ground (-)
25/(F49) No. 18 (+) — Chassis ground (-)
27/(F49) No. 16 (+) — Chassis ground (-)
Is voltage 0 V?

YES : Go to step **8B5**.

NO : Repair harness between ABSCM and ABS sensor.

8B5	CHECK ABS SENSOR MECHANICAL TROUBLE.
------------	---

CHECK : **Tightening torque:**
 $32 \pm 10 \text{ N}\cdot\text{m}$ ($3.3 \pm 1.0 \text{ kg}\cdot\text{m}$, $24 \pm 7 \text{ ft}\cdot\text{lb}$)
Are the ABS sensor installation bolts tightened securely?

YES : Go to next **CHECK** .

NO : Tighten ABS sensor installation bolts securely.

CHECK : **Tightening torque:**
 $13 \pm 3 \text{ N}\cdot\text{m}$ ($1.3 \pm 0.3 \text{ kg}\cdot\text{m}$, $9 \pm 2.2 \text{ ft}\cdot\text{lb}$)
Are the tone wheel installation bolts tightened securely?

YES : Go to next step.

NO : Tighten tone wheel installation bolts securely.

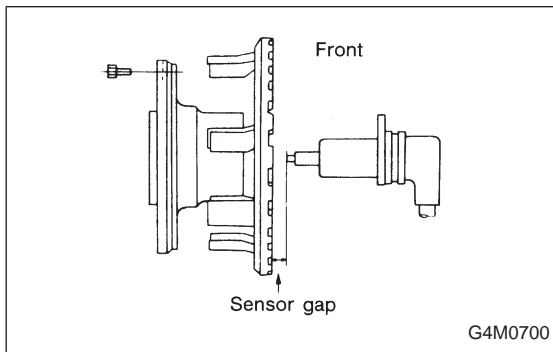

1) Measure tone wheel-to-pole piece gap over entire perimeter of the wheel.

CHECK : **Is the gap within the specifications shown in the following table?**

	Front wheel	Rear wheel
Specifications	0.9 — 1.4 mm (0.035 — 0.055 in)	0.7 — 1.2 mm (0.028 — 0.047 in)

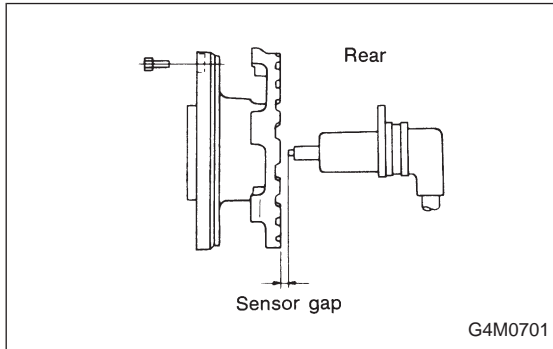

YES : Go to next step.

NO : Adjust the gap.

NOTE:

Adjust the gap using spacers (Part No. 26755AA000). If spacers cannot correct the gap, replace worn sensor or worn tone wheel.

2) Measure hub runout.

CHECK : **Is the runout less than 0.05 mm (0.0020 in)?**

YES : Go to step **8B6**.

NO : Repair hub.

8B6	CHECK POOR CONTACT IN CONNECTOR BETWEEN ABSCM AND ABS SENSOR.
------------	--

CHECK : *Is there poor contact in connectors between ABSCM and ABS sensor?*

YES : Repair connector.

NO : Go to step **8B7**.

8B7	CHECK ABSCM.
------------	---------------------

- 1) Connect all connectors.
- 2) Erase the memory.
- 3) Perform inspection mode.
- 4) Read out the trouble code.

CHECK : *Is the same trouble code as in the current diagnosis still being output?*

YES : Replace ABSCM.

NO : Go to next **CHECK** .

CHECK : *Are other trouble codes being output?*

YES : Proceed with the diagnosis corresponding to the trouble code.

NO : A temporary poor contact.

NOTE:

Check harness and connectors between ABSCM and ABS sensor.

**C: TROUBLE CODE 22 (FRONT RH)
TROUBLE CODE 24 (FRONT LH)
TROUBLE CODE 26 (REAR RH)
TROUBLE CODE 28 (REAR LH)
— ABNORMAL ABS SENSOR (ABNORMAL
ABS SENSOR SIGNAL) —**

DIAGNOSIS:

- Faulty ABS sensor signal (noise, irregular signal, etc.)
- Faulty harness/connector

TROUBLE SYMPTOM:

- ABS does not operate.

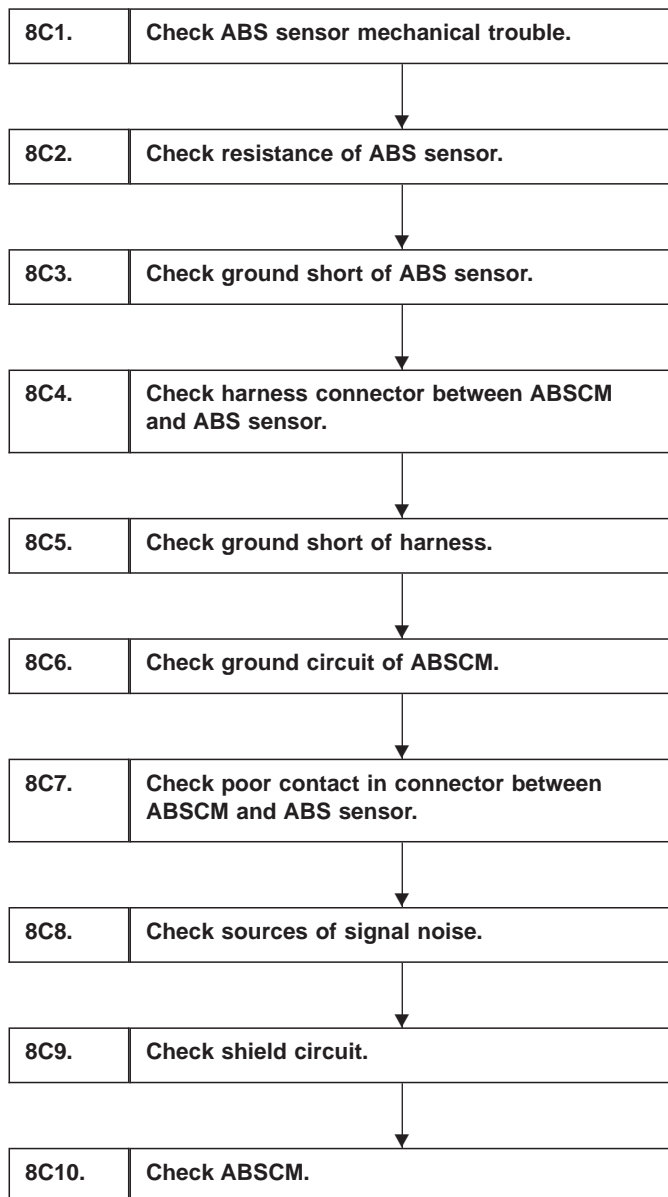

WIRING DIAGRAM:

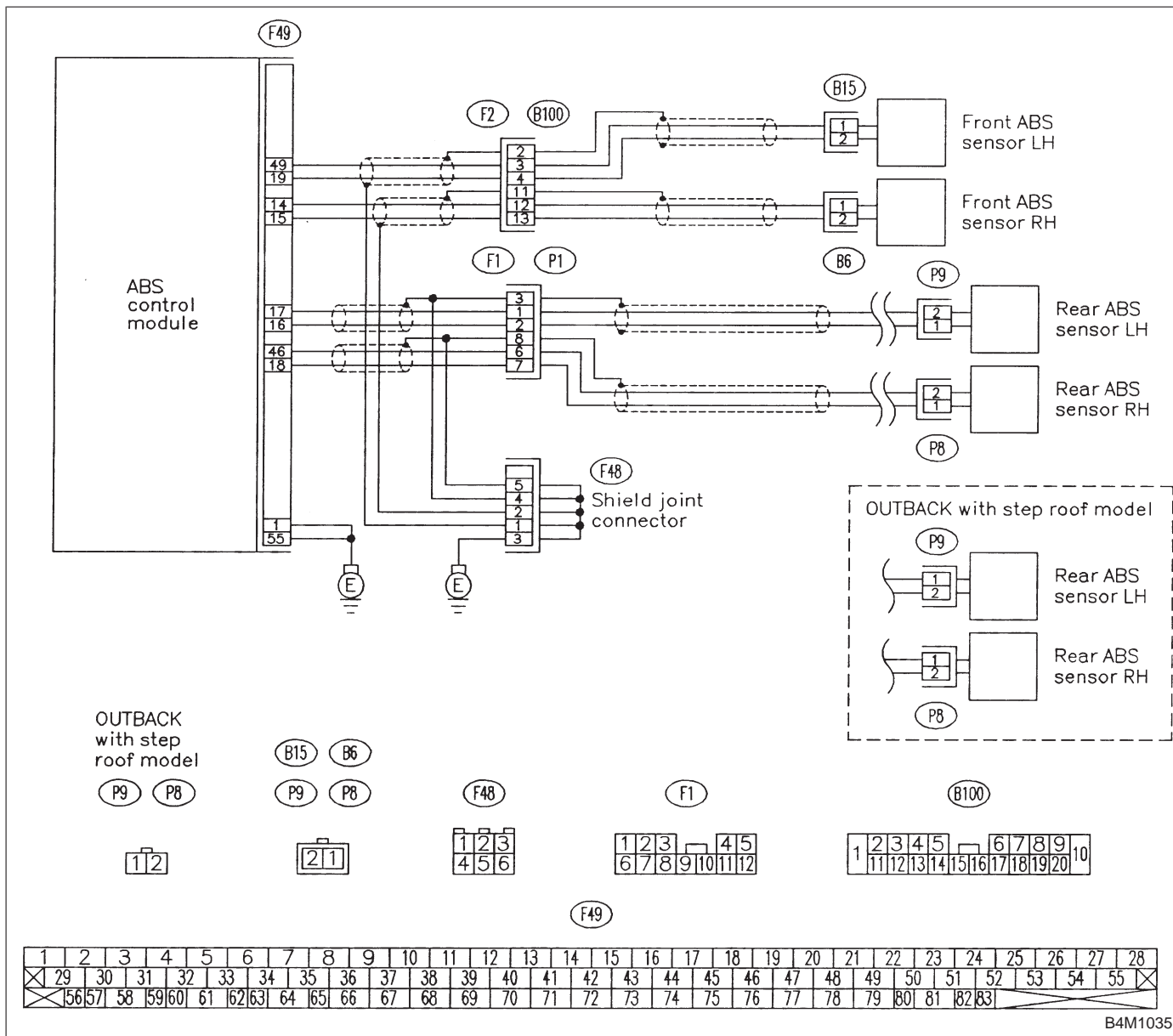

B4M1035

8C1 CHECK ABS SENSOR MECHANICAL TROUBLE.

- CHECK** : **Tightening torque:**
 $32 \pm 10 \text{ N}\cdot\text{m}$ ($3.3 \pm 1.0 \text{ kg}\cdot\text{m}$, $24 \pm 7 \text{ ft}\cdot\text{lb}$)
Are the ABS sensor installation bolts tightened securely?
- YES** : Go to next **CHECK** .
- NO** : Tighten ABS sensor installation bolts securely.
- CHECK** : **Tightening torque:**
 $13 \pm 3 \text{ N}\cdot\text{m}$ ($1.3 \pm 0.3 \text{ kg}\cdot\text{m}$, $9 \pm 2.2 \text{ ft}\cdot\text{lb}$)
Are the tone wheel installation bolts tightened securely?
- YES** : Go to next step.
- NO** : Tighten tone wheel installation bolts securely.

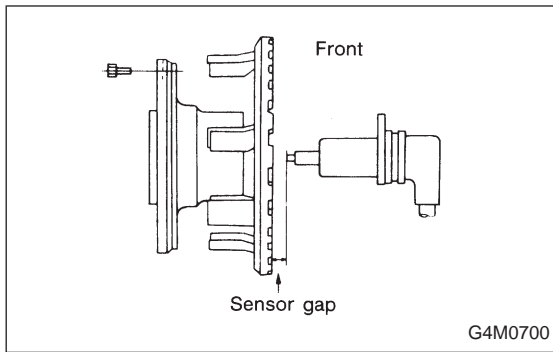

1) Measure tone wheel to pole piece gap over entire perimeter of the wheel.

CHECK : *Is the gap within the specifications shown in the following table?*

	Front wheel	Rear wheel
Specifications	0.9 — 1.4 mm (0.035 — 0.055 in)	0.7 — 1.2 mm (0.028 — 0.047 in)

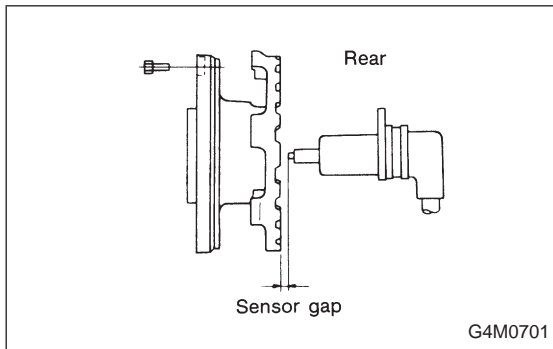

YES : Go to next **CHECK** .

NO : Adjust the gap.

NOTE:

Adjust the gap using spacer (Part No. 26755AA000). If spacers cannot correct the gap, replace worn sensor or worn tone wheel.

CHECK : *Is an oscilloscope available?*

YES : Go to next step.

NO : Go to step 13).

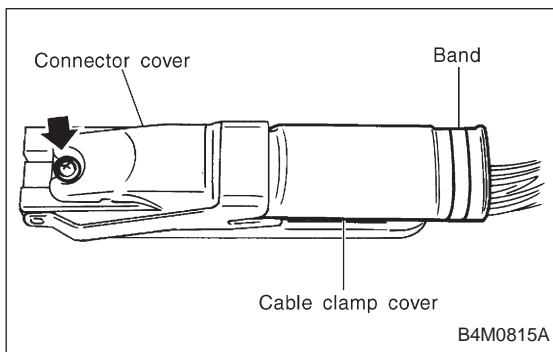

2) Raise all four wheels of ground.

3) Turn ignition switch OFF.

4) Disconnect connector from ABS control module.

5) Remove band.

6) Remove cable clamp cover.

7) Remove screws securing connector cover.

CAUTION:

Do not allow harness to catch on adjacent parts during installation.

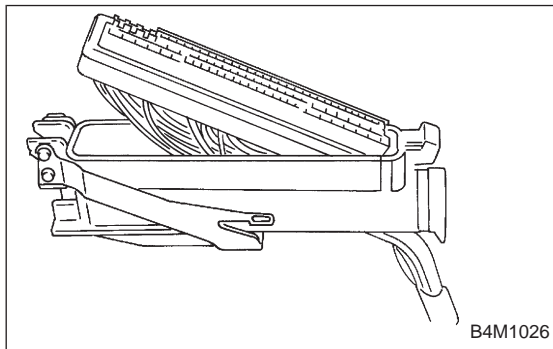

8) Remove connector cover.

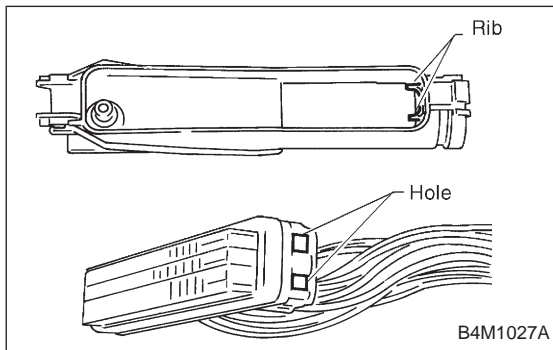

NOTE:

- To install, reverse above removal procedures.

- Align connector cover rib with connector hole before installation.

- 9) Connect connector to ABS control module.
- 10) Connect the oscilloscope to the ABS control module connector in accordance with trouble code.
- 11) Turn ignition switch ON.

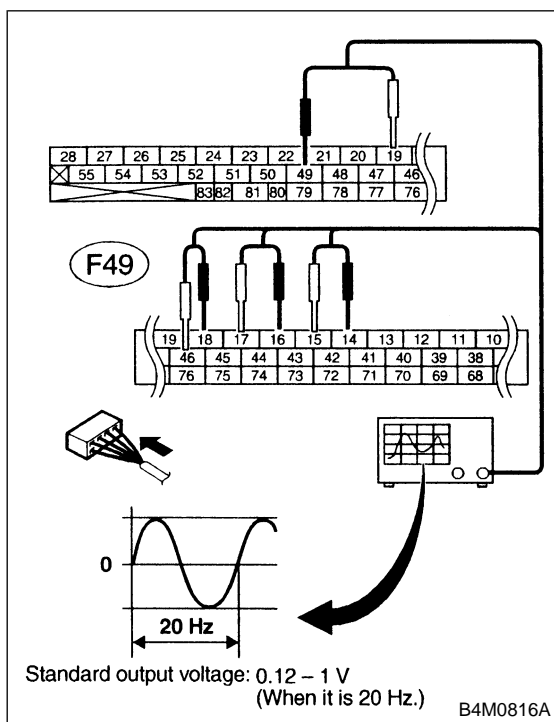

- 12) Rotate wheels and measure voltage at specified frequency.

NOTE:

When this inspection is completed, the ABS control module sometimes stores the trouble code 29.

TROUBLE CODE / Connector & terminal:

22 / (F49) No. 14 (+) — No. 15 (-)

24 / (F49) No. 49 (+) — No. 19 (-)

26 / (F49) No. 18 (+) — No. 46 (-)

28 / (F49) No. 16 (+) — No. 17 (-)

Specified voltage: 0.12 — 1 V (When it is 20 Hz.)

CHECK : *Is oscilloscope pattern smooth, as shown in figure?*

YES : Go to step 8C2.

NO : Go to next step.

- 13) Remove disc rotor from hub in accordance with trouble code.

CHECK : *Is the ABS sensor pole piece or the tone wheel contaminated by dirt or other foreign matter?*

YES : Thoroughly remove dirt or other foreign matter.

NO : Go to next **CHECK** .

CHECK : *Are there broken or damaged teeth in the ABS sensor pole piece or the tone wheel?*

YES : Replace ABS sensor or tone wheel.

NO : Go to next step.

- 14) Measure hub runout.

CHECK : *Is the runout less than 0.05 mm (0.0020 in)?*

YES : Go to step 8C2.

NO : Repair hub.

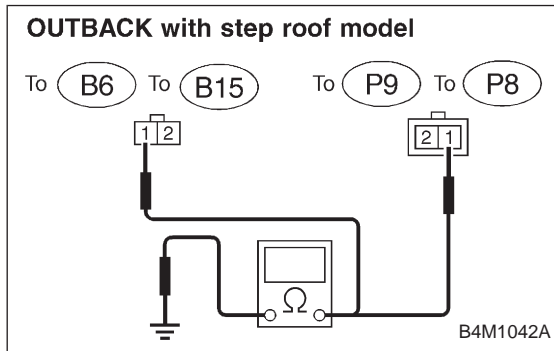
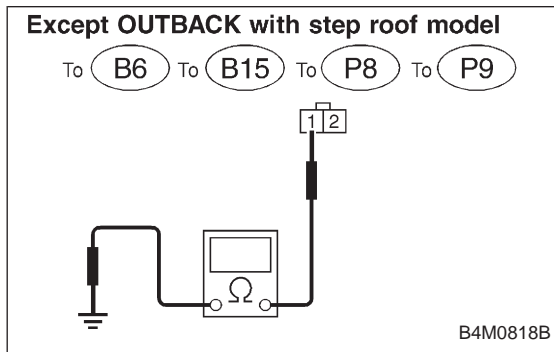
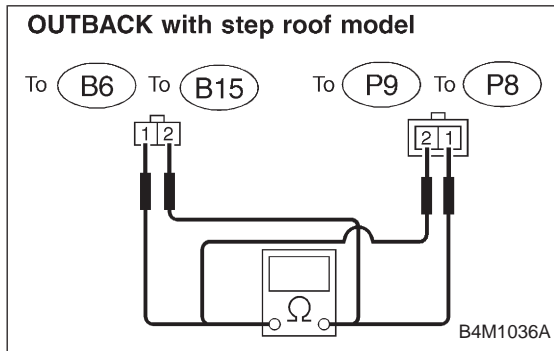
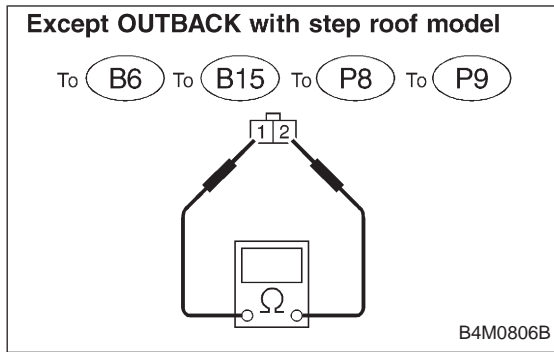

8C2 CHECK RESISTANCE OF ABS SENSOR.

- 1) Turn ignition switch OFF.
- 2) Disconnect connector from ABS sensor.
- 3) Measure resistance between ABS sensor connector terminals.

CHECK : *Trouble code/Connector & terminal*
 22/to (B6) No. 1 — No. 2
 24/to (B15) No. 1 — No. 2
 26/to (P8) No. 1 — No. 2
 28/to (P9) No. 1 — No. 2
Is resistance 0.8 — 1.2 kΩ?

- YES** : Go to step 8C3.
NO : Replace ABS sensor.

8C3 CHECK GROUND SHORT OF ABS SENSOR.

Measure resistance between ABS sensor and chassis ground.

CHECK : *Trouble code/Connector & terminal*
 22/to (B6) No. 1 — Chassis ground
 24/to (B15) No. 1 — Chassis ground
 26/to (P8) No. 1 — Chassis ground
 28/to (P9) No. 1 — Chassis ground
Is resistance more than 1 MΩ?

- YES** : Go to step 8C4.
NO : Replace ABS sensor.

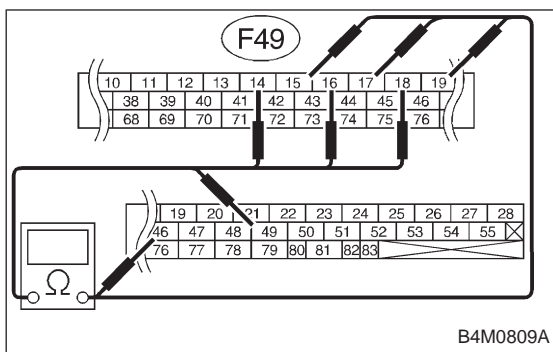

8C4 CHECK HARNESS CONNECTOR BETWEEN ABSCM AND ABS SENSOR.

- 1) Connect connector to ABS sensor.
- 2) Disconnect connector from ABS control module.
- 3) Measure resistance at ABSCM connector terminals.

CHECK : *Trouble code/Connector & terminal*
22/(F49) No. 14 — No. 15
24/(F49) No. 49 — No. 19
26/(F49) No. 18 — No. 46
28/(F49) No. 16 — No. 17
Is resistance 0.8 — 1.2 kΩ?

- YES** : Go to step **8C5**.
- NO** : Repair harness connector between ABSCM and ABS sensor.

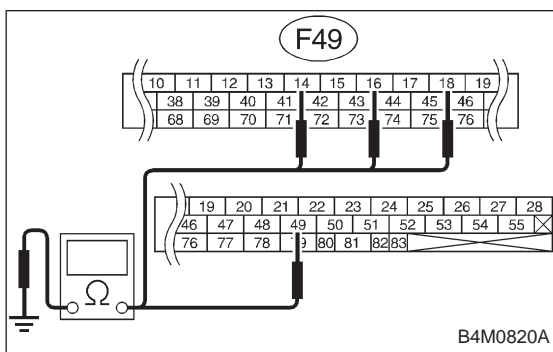

8C5 CHECK GROUND SHORT OF HARNESS.

Measure resistance between ABSCM connector and chassis ground.

CHECK : *Trouble code/Connector & terminal*
22/(F49) No. 14 — Chassis ground
24/(F49) No. 49 — Chassis ground
26/(F49) No. 18 — Chassis ground
28/(F49) No. 16 — Chassis ground
Is resistance more than 1 MΩ?

- YES** : Go to step **8C6**.
- NO** : Repair harness connector between ABSCM and ABS sensor.

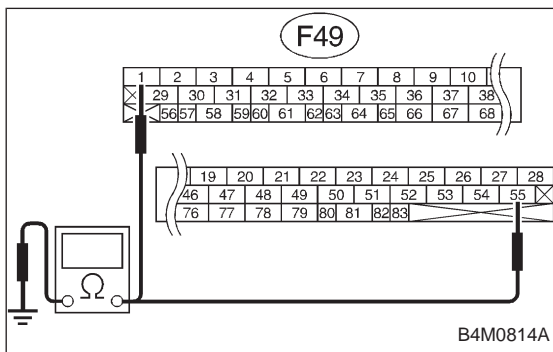

8C6 CHECK GROUND CIRCUIT OF ABSCM.

Measure resistance between ABSCM and chassis ground.

CHECK : *Connector & terminal*
(F49) No. 1 — GND
(F49) No. 55 — GND
Is resistance less than 0.5 Ω?

- YES** : Go to step **8C7**.
- NO** : Repair ABSCM ground harness.

8C7	CHECK POOR CONTACT IN CONNECTOR BETWEEN ABSCM AND ABS SENSOR.
------------	--

CHECK : *Is there poor contact in connectors between ABSCM and ABS sensor?*

YES : Repair connector.

NO : Go to step **8C8**.

8C8	CHECK SOURCES OF SIGNAL NOISE.
------------	---------------------------------------

CHECK : *Is the car telephone or the wireless transmitter properly installed?*

YES : Go to next **CHECK** .

NO : Properly install the car telephone or the wireless transmitter.

CHECK : *Are noise sources (such as an antenna) installed near the sensor harness?*

YES : Install the noise sources apart from the sensor harness.

NO : Go to step **8C9**.

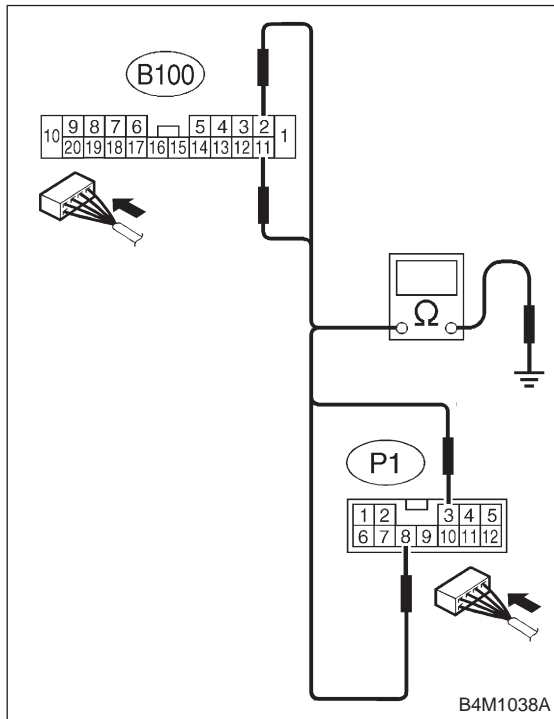

8C9	CHECK SHIELD CIRCUIT.
------------	------------------------------

- 1) Connect all connectors.
- 2) Measure resistance between shield connector and chassis ground.

CHECK : *Trouble code/Connector & terminal
 22/(B100) No. 11 — Chassis ground
 24/(B100) No. 2 — Chassis ground
 26/(P1) No. 8 — Chassis ground
 28/(P1) No. 3 — Chassis ground
 Is resistance less than 0.5 Ω?*

YES : Go to step **8C10**.

NO : Repair shield harness.

8C10	CHECK ABSCM.
-------------	---------------------

- 1) Connect all connectors.
- 2) Erase the memory.
- 3) Perform inspection mode.
- 4) Read out the trouble code.

CHECK : *Is the same trouble code as in the current diagnosis still being output?*

YES : Replace ABSCM.

NO : Go to next **CHECK** .

CHECK : *Are other trouble codes being output?*

YES : Proceed with the diagnosis corresponding to the trouble code.

NO : A temporary noise interference.

**D: TROUBLE CODE 29
— ABNORMAL ABS SENSOR SIGNAL (ANY
ONE OF FOUR) —****DIAGNOSIS:**

- Faulty ABS sensor signal (noise, irregular signal, etc.)
- Faulty tone wheel
- Wheels turning freely for a long time

TROUBLE SYMPTOM:

- ABS does not operate.

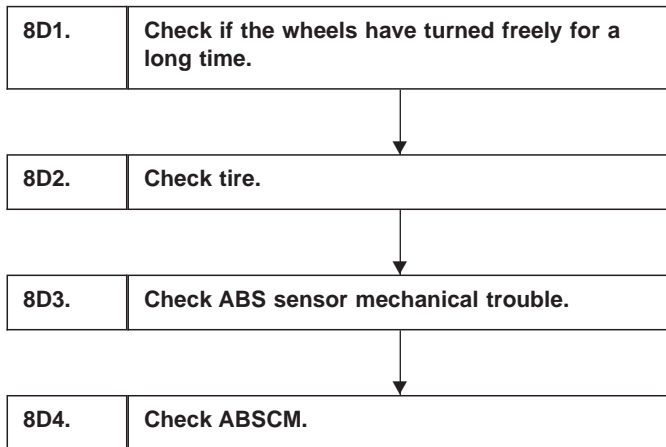

WIRING DIAGRAM:

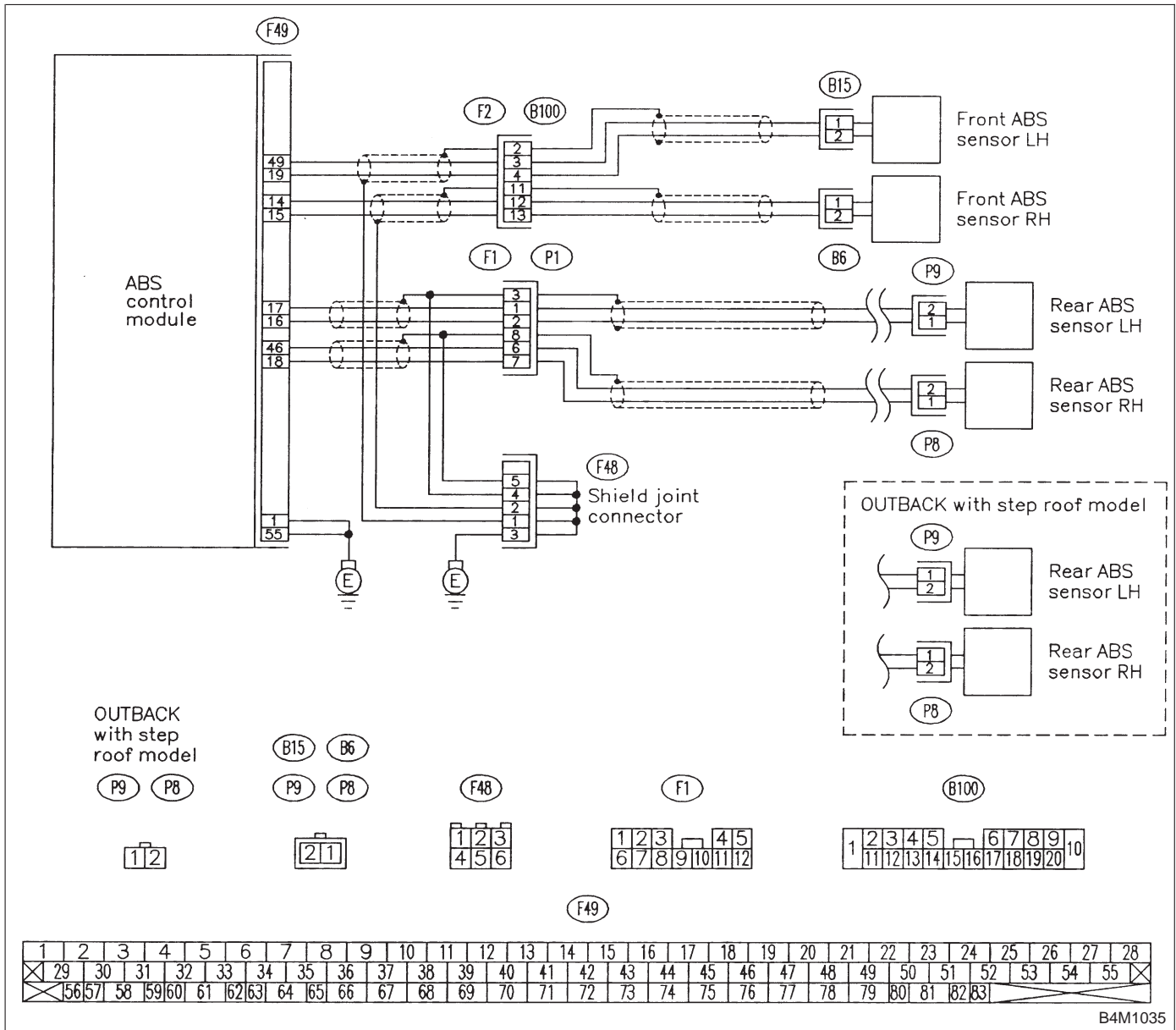

8D1 CHECK IF THE WHEELS HAVE TURNED FREELY FOR A LONG TIME.

CHECK : Check if the wheels have been turned freely for more than one minute, such as when the vehicle is jacked-up, under full-lock cornering or when tire is not in contact with road surface.

YES : The ABS is normal. Erase the trouble code.

NOTE:
When the wheels turn freely for a long time, such as when the vehicle is towed or jacked-up, or when steering wheel is continuously turned all the way, this trouble code may sometimes occur.

NO : Go to step **8D2**.

8D2	CHECK TIRE.
------------	--------------------

- CHECK** : *Are the tire specifications correct?*
- YES** : Go to next **CHECK** .
- NO** : Replace tire.
- CHECK** : *Is the tire worn excessively?*
- YES** : Replace tire.
- NO** : Go to next **CHECK** .
- CHECK** : *Is the tire pressure correct?*
- YES** : Go to step **8D3**.
- NO** : Adjust tire pressure.

8D3	CHECK ABS SENSOR MECHANICAL TROUBLE.
------------	---

- CHECK** : *Tightening torque:
32±10 N·m (3.3±1.0 kg-m, 24±7 ft-lb)
Are the ABS sensor installation bolts tightened securely?*
- YES** : Go to next **CHECK** .
- NO** : Tighten ABS sensor installation bolts securely.
- CHECK** : *Tightening torque:
13±3 N·m (1.3±0.3 kg-m, 9±2.2 ft-lb)
Are the tone wheel installation bolts tightened securely?*
- YES** : Go to next step.
- NO** : Tighten tone wheel installation bolts securely.

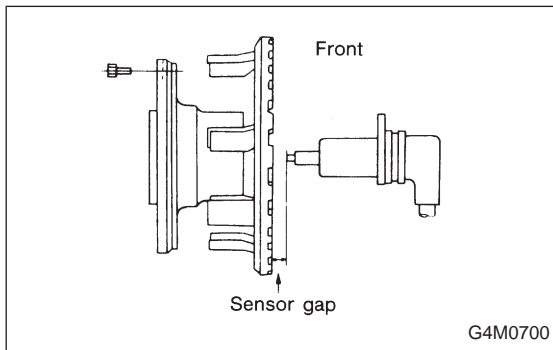

1) Measure tone wheel to pole piece gap over entire perimeter of the wheel.

- CHECK** : *Is the gap within the specifications shown in the following table?*

	Front wheel	Rear wheel
Specifications	0.9 — 1.4 mm (0.035 — 0.055 in)	0.7 — 1.2 mm (0.028 — 0.047 in)

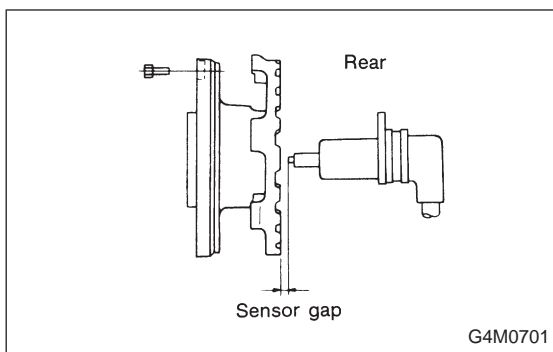

YES : Go to next **CHECK** .

NO : Adjust the gap.

NOTE:

Adjust the gap using spacer (Part No. 26755AA000). If spacers cannot correct the gap, replace worn sensor or worn tone wheel.

CHECK : *Is an oscilloscope available?*

YES : Go to next step.

NO : Go to step 10).

- 2) Raise all four wheels of ground.
- 3) Turn ignition switch OFF.
- 4) Disconnect connector from ABS control module.
- 5) Disconnect connector cover from connector.
<Ref. to 4-4c [T8C1] steps 5) to 8).>
- 6) Connect connector to ABS control module.
- 7) Connect the oscilloscope to the ABS control module connector.
- 8) Turn ignition switch ON.

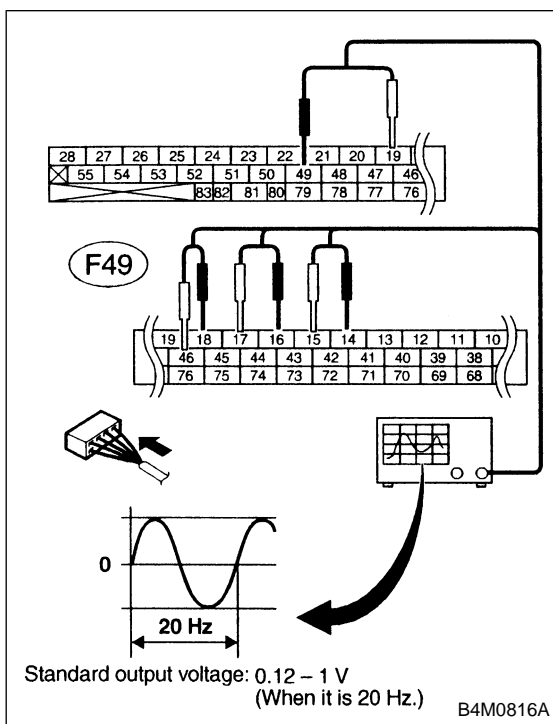

- 9) Rotate wheels and measure voltage at specified frequency.

NOTE:

When this inspection is completed, the ABS control module sometimes stores the trouble code 29.

TROUBLE CODE / Connector & terminal:

(F49) No. 14 (+) — No. 15 (-) (Front RH)

(F49) No. 49 (+) — No. 19 (-) (Front LH)

(F49) No. 18 (+) — No. 46 (-) (Rear RH)

(F49) No. 16 (+) — No. 17 (-) (Rear LH)

Specified voltage: 0.12 — 1 V (When it is 20 Hz.)

CHECK : *Is oscilloscope pattern smooth, as shown in figure?*

YES : Go to step 8D4.

NO : Go to next step.

10) Remove disc rotor from hub.

CHECK : *Is the ABS sensor pole piece or the tone wheel contaminated by dirt or other foreign matter?*

YES : Thoroughly remove dirt or other foreign matter.

NO : Go to next **CHECK** .

CHECK : *Are there broken or damaged teeth in the ABS sensor pole piece or the tone wheel?*

YES : Replace ABS sensor or tone wheel.

NO : Go to next step.

11) Measure hub runout.

CHECK : *Is the runout less than 0.05 mm (0.0020 in)?*

YES : Go to step 8D4.

NO : Repair hub.

8D4	CHECK ABSCM.
------------	---------------------

1) Turn ignition switch to OFF.

2) Connect all connectors.

3) Erase the memory.

4) Perform inspection mode.

5) Read out the trouble code.

CHECK : *Is the same trouble code as in the current diagnosis still being output?*

YES : Replace ABSCM.

NO : Go to next **CHECK** .

CHECK : *Are other trouble codes being output?*

YES : Proceed with the diagnosis corresponding to the trouble code.

NO : A temporary poor contact.

**E: TROUBLE CODE 31 (FRONT RH)
TROUBLE CODE 33 (FRONT LH)
TROUBLE CODE 35 (REAR RH)
TROUBLE CODE 37 (REAR LH)
— ABNORMAL INLET SOLENOID VALVE
CIRCUIT(S) IN HYDRAULIC UNIT —**

DIAGNOSIS:

- Faulty harness/connector
- Faulty inlet solenoid valve in hydraulic unit

TROUBLE SYMPTOM:

- ABS does not operate.

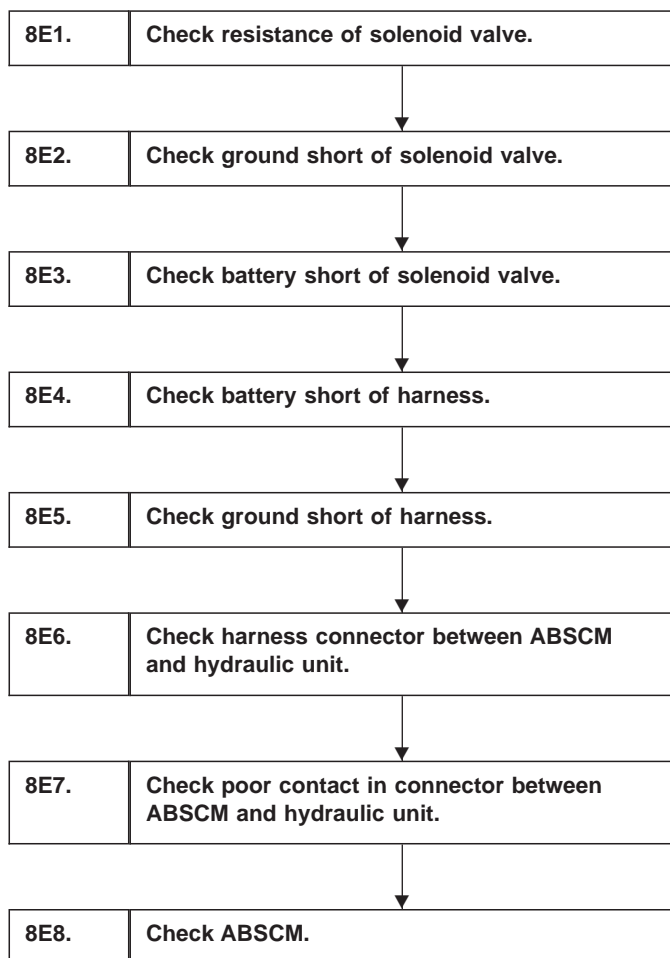

WIRING DIAGRAM:

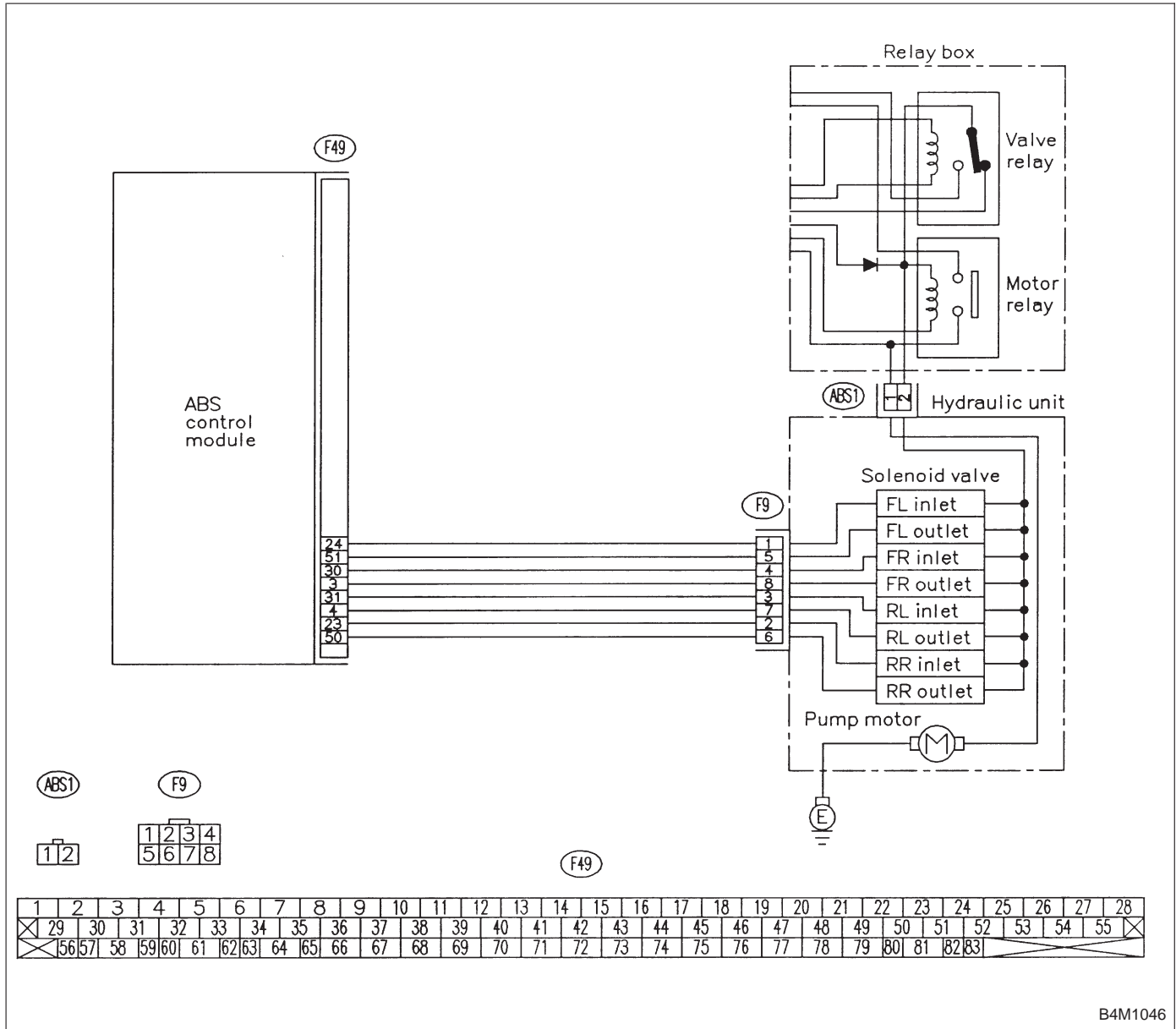

B4M1046

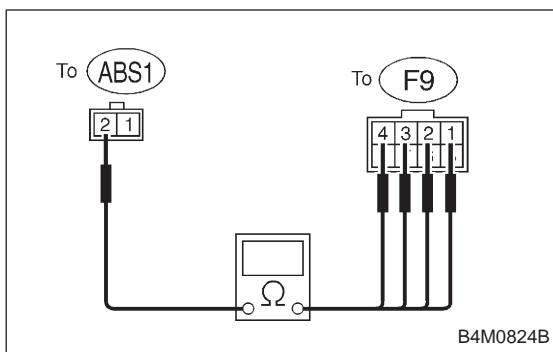

8E1 CHECK RESISTANCE OF SOLENOID VALVE.

- 1) Turn ignition switch to OFF.
- 2) Disconnect two connectors (ABS1, F9) from hydraulic unit.
- 3) Measure resistance between hydraulic unit connector terminals.

CHECK : *Trouble code/Connector & terminal*
 31/to (F9) No. 4 — to (ABS1) No. 2
 33/to (F9) No. 1 — to (ABS1) No. 2
 35/to (F9) No. 2 — to (ABS1) No. 2
 37/to (F9) No. 3 — to (ABS1) No. 2
Is resistance 8.5±0.7 Ω?

- YES** : Go to step 8E2.
NO : Replace hydraulic unit.

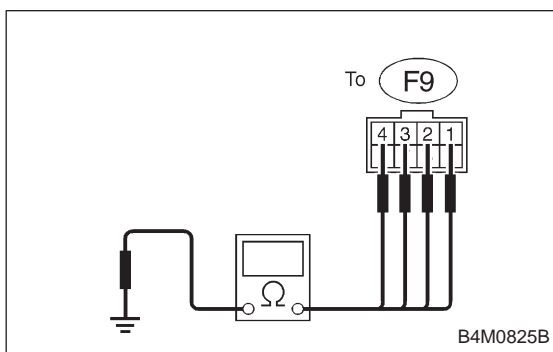

8E2 CHECK GROUND SHORT OF SOLENOID VALVE.

Measure resistance between hydraulic unit connector and chassis ground.

CHECK : *Trouble code/Connector & terminal*
 31/to (F9) No. 4 — Chassis ground
 33/to (F9) No. 1 — Chassis ground
 35/to (F9) No. 2 — Chassis ground
 37/to (F9) No. 3 — Chassis ground
Is resistance more than 1 MΩ?

- YES** : Go to step 8E3.
NO : Replace hydraulic unit.

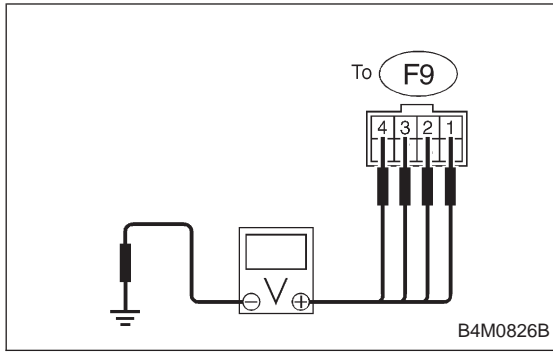

8E3 CHECK BATTERY SHORT OF SOLENOID VALVE.

- 1) Disconnect connector from ABSCM.
- 2) Turn ignition switch to ON.
- 3) Measure voltage between hydraulic unit connector and chassis ground.

CHECK : *Trouble code/Connector & terminal*
31/to (F9) No. 4 (+) — Chassis ground (-)
33/to (F9) No. 1 (+) — Chassis ground (-)
35/to (F9) No. 2 (+) — Chassis ground (-)
37/to (F9) No. 3 (+) — Chassis ground (-)
Is voltage 0 V?

YES : Go to next step.

NO : Replace hydraulic unit.

- 4) Turn ignition switch to OFF.
- 5) Measure voltage between hydraulic unit connector and chassis ground.

CHECK : *Trouble code/Connector & terminal*
31/to (F9) No. 4 (+) — Chassis ground (-)
33/to (F9) No. 1 (+) — Chassis ground (-)
35/to (F9) No. 2 (+) — Chassis ground (-)
37/to (F9) No. 3 (+) — Chassis ground (-)
Is voltage 0 V?

YES : Go to step **8E4**.

NO : Replace hydraulic unit.

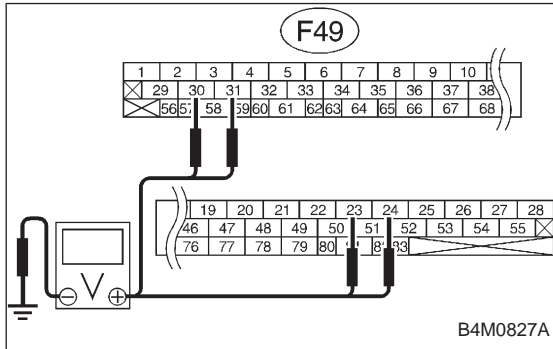

8E4 CHECK BATTERY SHORT OF HARNESS.

- 1) Turn ignition switch to ON.
- 2) Measure voltage between ABSCM connector and chassis ground.

CHECK : *Trouble code/Connector & terminal*
31/(F49) No. 30 (+) — Chassis ground (-)
33/(F49) No. 24 (+) — Chassis ground (-)
35/(F49) No. 23 (+) — Chassis ground (-)
37/(F49) No. 31 (+) — Chassis ground (-)
Is voltage 0 V?

YES : Go to next step.

NO : Repair harness between ABSCM and hydraulic unit.

- 3) Turn ignition switch to OFF.
- 4) Measure voltage between ABSCM connector and chassis ground.

CHECK : *Trouble code/Connector & terminal*
31/(F49) No. 30 (+) — Chassis ground (-)
33/(F49) No. 24 (+) — Chassis ground (-)
35/(F49) No. 23 (+) — Chassis ground (-)
37/(F49) No. 31 (+) — Chassis ground (-)
Is voltage 0 V?

YES : Go to step **8E5**.

NO : Repair harness between ABSCM and hydraulic unit.

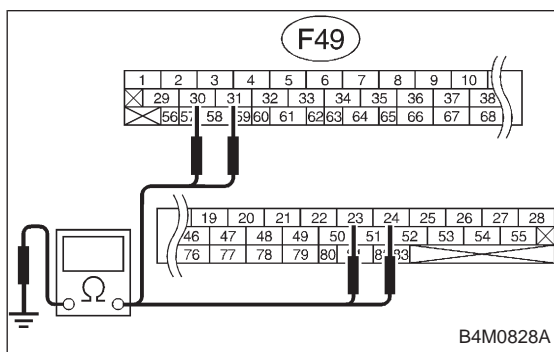

8E5 CHECK GROUND SHORT OF HARNESS.

Measure resistance between ABSCM connector and chassis ground.

CHECK : *Trouble code/Connector & terminal*
31/(F49) No. 30 — Chassis ground
33/(F49) No. 24 — Chassis ground
35/(F49) No. 23 — Chassis ground
37/(F49) No. 31 — Chassis ground
Is resistance more than 1 MΩ?

YES : Go to step **8E6**.

NO : Repair harness between ABSCM and hydraulic unit.

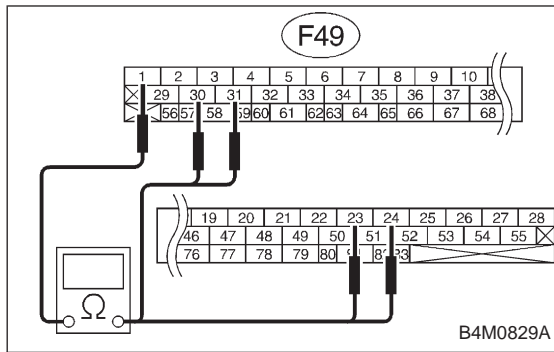
**8E6****CHECK HARNESS CONNECTOR BETWEEN ABSCM AND HYDRAULIC UNIT.**

- 1) Connect connector to hydraulic unit.
- 2) Measure resistance between ABSCM connector terminals.

CHECK : *Trouble code/Connector & terminal*
31/(F49) No. 30 — No. 1
33/(F49) No. 24 — No. 1
35/(F49) No. 23 — No. 1
37/(F49) No. 31 — No. 1
Is resistance $9.0 \pm 0.7 \Omega$?

YES : Go to step **8E7**.

NO : Repair harness connector between ABSCM and hydraulic unit.

8E7**CHECK POOR CONTACT IN CONNECTOR BETWEEN ABSCM AND HYDRAULIC UNIT.**

CHECK : *Is there poor contact in connectors between ABSCM and hydraulic unit?*

YES : Repair connector.

NO : Go to step **8E8**.

8E8**CHECK ABSCM.**

- 1) Connect all connectors.
- 2) Erase the memory.
- 3) Perform inspection mode.
- 4) Read out the trouble code.

CHECK : *Is the same trouble code as in the current diagnosis still being output?*

YES : Replace ABSCM.

NO : Go to next **CHECK** .

CHECK : *Are other trouble codes being output?*

YES : Proceed with the diagnosis corresponding to the trouble code.

NO : A temporary poor contact.

**F: TROUBLE CODE 32 (FRONT RH)
TROUBLE CODE 34 (FRONT LH)
TROUBLE CODE 36 (REAR RH)
TROUBLE CODE 38 (REAR LH)
— ABNORMAL OUTLET SOLENOID VALVE
CIRCUIT(S) IN HYDRAULIC UNIT —**

DIAGNOSIS:

- Faulty harness/connector
- Faulty outlet solenoid valve in hydraulic unit

TROUBLE SYMPTOM:

- ABS does not operate.

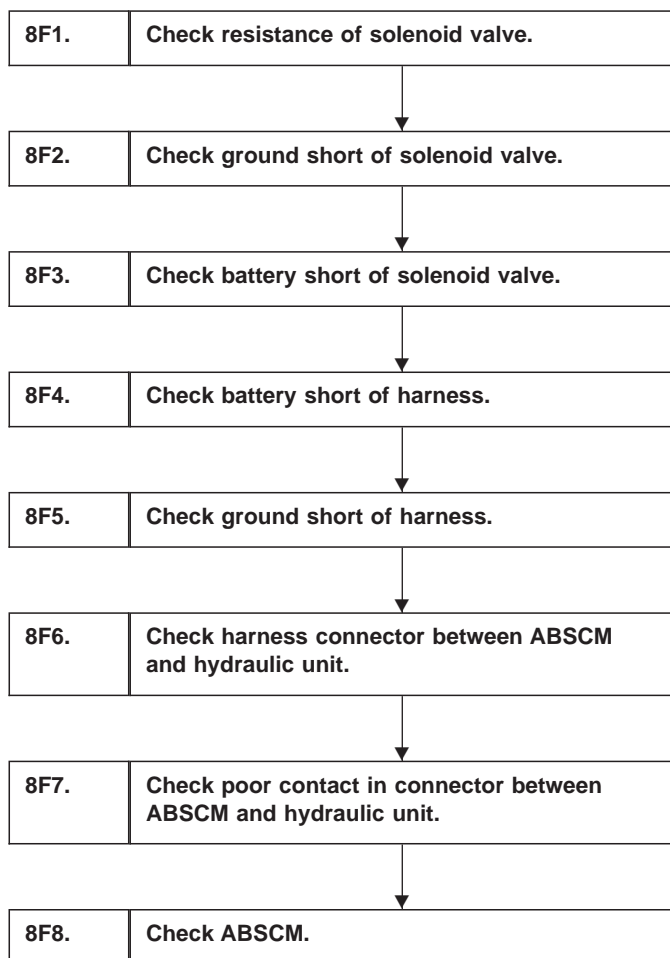

WIRING DIAGRAM:

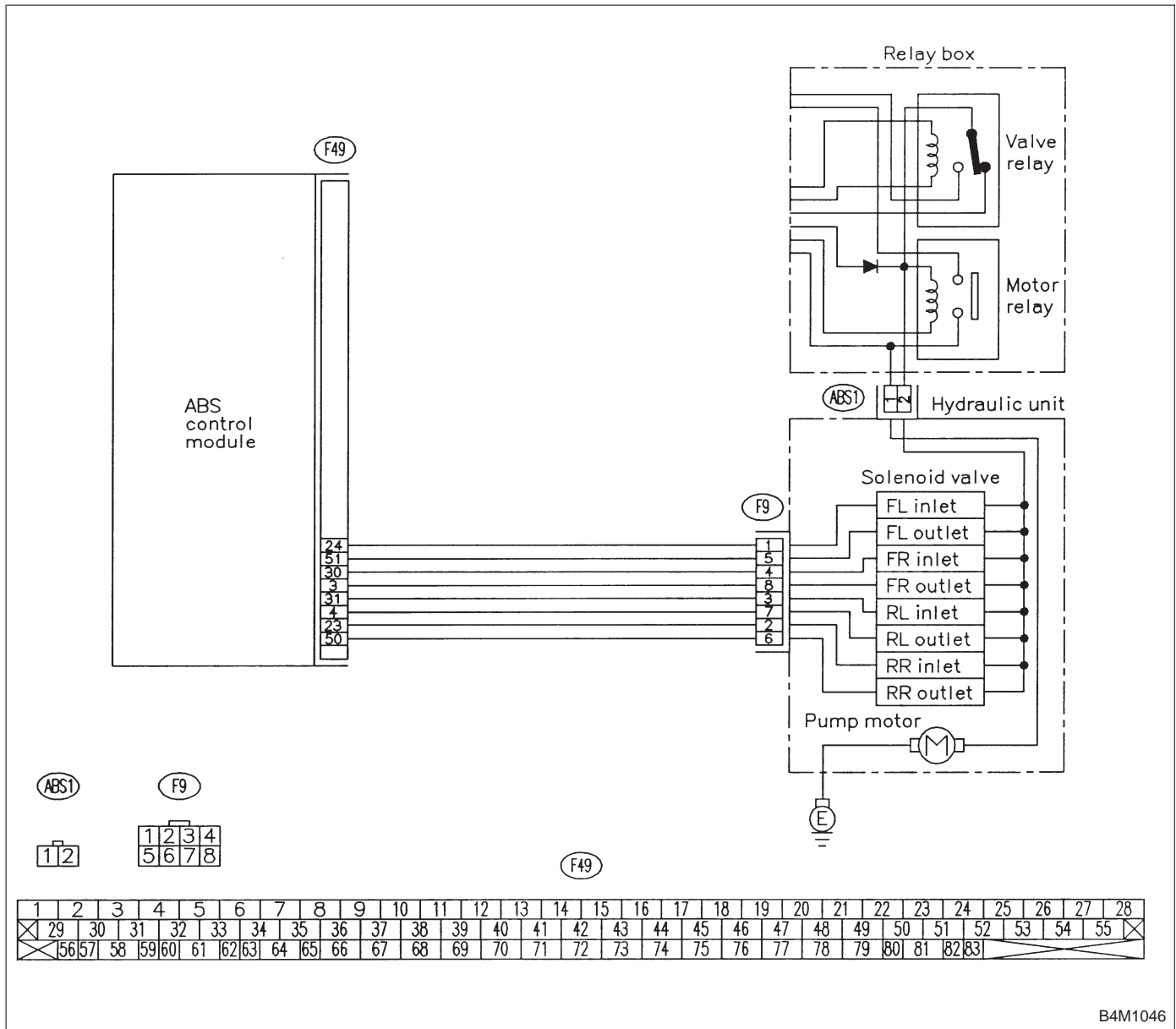

B4M1046

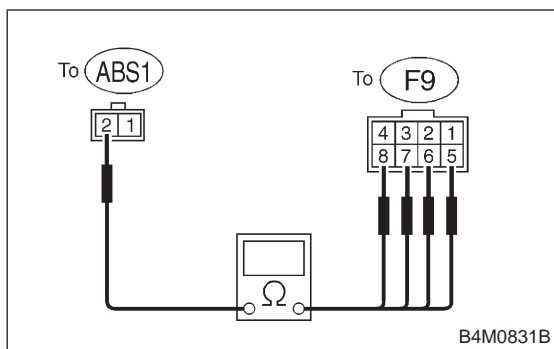
**8F1****CHECK RESISTANCE OF SOLENOID VALVE.**

- 1) Turn ignition switch to OFF.
- 2) Disconnect two connectors (ABS1, F9) from hydraulic unit.
- 3) Measure resistance between hydraulic unit connector terminals.

CHECK : *Trouble code/Connector & terminal*
32/to (F9) No. 8 — to (ABS1) No. 2
34/to (F9) No. 5 — to (ABS1) No. 2
36/to (F9) No. 6 — to (ABS1) No. 2
38/to (F9) No. 7 — to (ABS1) No. 2
Is resistance $4.3 \pm 0.5 \Omega$?

YES : Go to step **8F2**.

NO : Replace hydraulic unit.

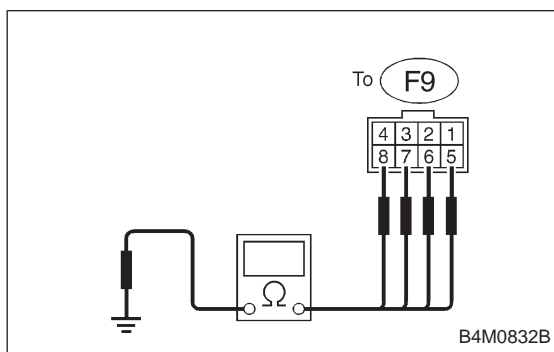
**8F2****CHECK GROUND SHORT OF SOLENOID VALVE.**

Measure resistance between hydraulic unit connector and chassis ground.

CHECK : *Trouble code/Connector & terminal*
32/to (F9) No. 8 — Chassis ground
34/to (F9) No. 5 — Chassis ground
36/to (F9) No. 6 — Chassis ground
38/to (F9) No. 7 — Chassis ground
Is resistance more than $1 M\Omega$?

YES : Go to step **8F3**.

NO : Replace hydraulic unit.

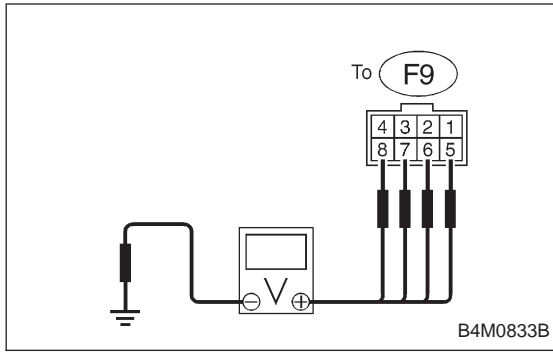

8F3 CHECK BATTERY SHORT OF SOLENOID VALVE.

- 1) Disconnect connector from ABSCM.
- 2) Turn ignition switch to ON.
- 3) Measure voltage between hydraulic unit connector and chassis ground.

CHECK : *Trouble code/Connector & terminal*
32/to (F9) No. 8 (+) — Chassis ground (-)
34/to (F9) No. 5 (+) — Chassis ground (-)
36/to (F9) No. 6 (+) — Chassis ground (-)
38/to (F9) No. 7 (+) — Chassis ground (-)
Is voltage 0 V?

YES : Go to next step.

NO : Replace hydraulic unit.

- 4) Turn ignition switch to OFF.
- 5) Measure voltage between hydraulic unit connector and chassis ground.

CHECK : *Trouble code/Connector & terminal*
32/to (F9) No. 8 (+) — Chassis ground (-)
34/to (F9) No. 5 (+) — Chassis ground (-)
36/to (F9) No. 6 (+) — Chassis ground (-)
38/to (F9) No. 7 (+) — Chassis ground (-)
Is voltage 0 V?

YES : Go to step **8F4**.

NO : Replace hydraulic unit.

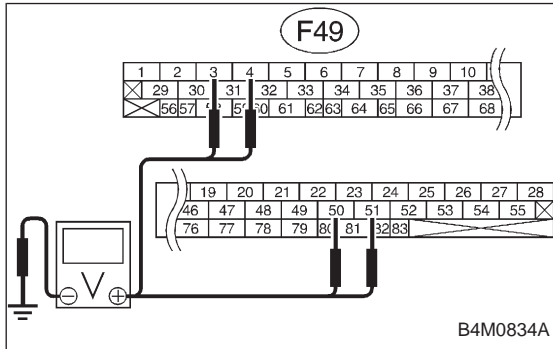

8F4 CHECK BATTERY SHORT OF HARNESS.

- 1) Turn ignition switch to ON.
- 2) Measure voltage between ABSCM connector and chassis ground.

CHECK : *Trouble code/Connector & terminal*
32/(F49) No. 3 (+) — Chassis ground (-)
34/(F49) No. 51 (+) — Chassis ground (-)
36/(F49) No. 50 (+) — Chassis ground (-)
38/(F49) No. 4 (+) — Chassis ground (-)
Is voltage 0 V?

YES : Go to next step.

NO : Repair harness between ABSCM and hydraulic unit.

- 3) Turn ignition switch to OFF.
- 4) Measure voltage between ABSCM connector and chassis ground.

CHECK : *Trouble code/Connector & terminal*
32/(F49) No. 3 (+) — Chassis ground (-)
34/(F49) No. 51 (+) — Chassis ground (-)
36/(F49) No. 50 (+) — Chassis ground (-)
38/(F49) No. 4 (+) — Chassis ground (-)
Is voltage 0 V?

YES : Go to step **8F5**.

NO : Repair harness between ABSCM and hydraulic unit.

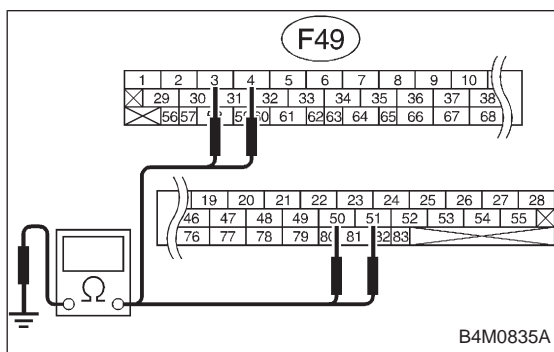

8F5 CHECK GROUND SHORT OF HARNESS.

Measure resistance between ABSCM connector and chassis ground.

CHECK : *Trouble code/Connector & terminal*
32/(F49) No. 3 — Chassis ground
34/(F49) No. 51 — Chassis ground
36/(F49) No. 50 — Chassis ground
38/(F49) No. 4 — Chassis ground
Is resistance more than 1 MΩ?

YES : Go to step **8F6**.

NO : Repair harness between ABSCM and hydraulic unit.

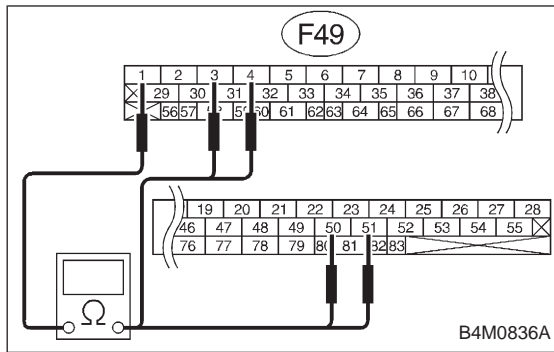
**8F6****CHECK HARNESS CONNECTOR BETWEEN ABSCM AND HYDRAULIC UNIT.**

- 1) Connect connector to hydraulic unit.
- 2) Measure resistance between ABSCM connector terminals.

CHECK : *Trouble code/Connector & terminal*
32/(F49) No. 3 — No. 1
34/(F49) No. 51 — No. 1
36/(F49) No. 50 — No. 1
38/(F49) No. 4 — No. 1
Is resistance $4.8 \pm 0.5 \Omega$?

YES : Go to step **8F7**.

NO : Repair harness connector between ABSCM and hydraulic unit.

8F7**CHECK POOR CONTACT IN CONNECTOR BETWEEN ABSCM AND HYDRAULIC UNIT.**

CHECK : *Is there poor contact in connectors between ABSCM and hydraulic unit?*

YES : Repair connector.

NO : Go to step **8F8**.

8F8**CHECK ABSCM.**

- 1) Connect all connectors.
- 2) Erase the memory.
- 3) Perform inspection mode.
- 4) Read out the trouble code.

CHECK : *Is the same trouble code as in the current diagnosis still being output?*

YES : Replace ABSCM.

NO : Go to next **CHECK** .

CHECK : *Are other trouble codes being output?*

YES : Proceed with the diagnosis corresponding to the trouble code.

NO : A temporary poor contact.

**G: TROUBLE CODE 41
— ABNORMAL ABS CONTROL MODULE —**

DIAGNOSIS:

- Faulty ABSCM

TROUBLE SYMPTOM:

- ABS does not operate.

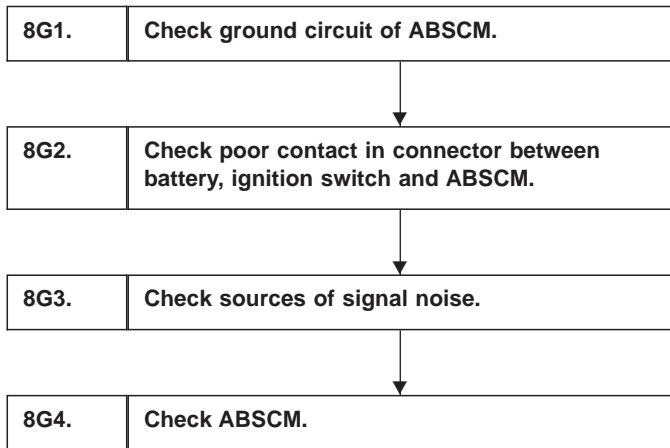

WIRING DIAGRAM:

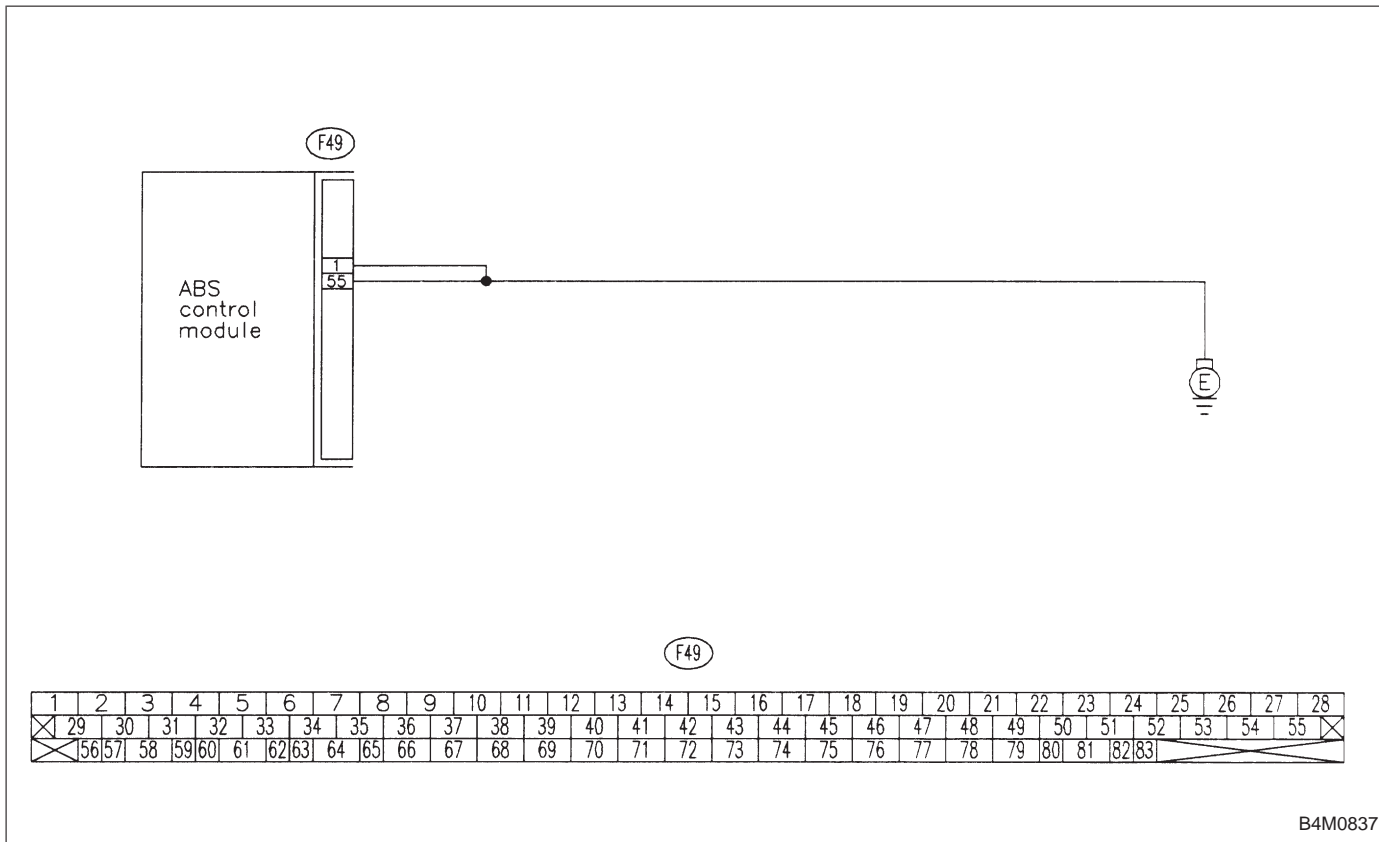

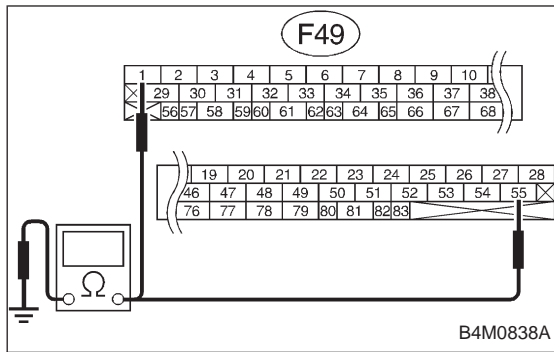

8G1	CHECK GROUND CIRCUIT OF ABSCM.
------------	---------------------------------------

- 1) Turn ignition switch to OFF.
- 2) Disconnect connector from ABSCM.
- 3) Measure resistance between ABSCM and chassis ground.

CHECK : *Connector & terminal (F49) No. 1 — Chassis ground (F49) No. 55 — Chassis ground Is resistance less than 0.5 Ω?*

YES : Go to step **8G2**.

NO : Repair ABSCM ground harness.

8G2	CHECK POOR CONTACT IN CONNECTORS BETWEEN BATTERY, IGNITION SWITCH AND ABSCM.
------------	---

CHECK : *Is there poor contact in connectors between battery, ignition switch and ABSCM?*

YES : Repair connector.

NO : Go to step **8G3**.

8G3	CHECK SOURCES OF SIGNAL NOISE.
------------	---------------------------------------

CHECK : *Is the car telephone or the wireless transmitter properly installed?*

YES : Go to next **CHECK** .

NO : Properly install the car telephone or the wireless transmitter.

CHECK : *Are noise sources (such as an antenna) installed near the sensor harness?*

YES : Install the noise sources apart from the sensor harness.

NO : Go to step **8G4**.

8G4**CHECK ABSCM.**

- 1) Connect all connectors.
- 2) Erase the memory.
- 3) Perform inspection mode.
- 4) Read out the trouble code.

CHECK : *Is the same trouble code as in the current diagnosis still being output?*

YES : Replace ABSCM.

NO : Go to next **CHECK** .

CHECK : *Are other trouble codes being output?*

YES : Proceed with the diagnosis corresponding to the trouble code.

NO : A temporary poor contact.

**H: TROUBLE CODE 42
— SOURCE VOLTAGE IS LOW. —****DIAGNOSIS:**

- Power source voltage of the ABSCM is low.

TROUBLE SYMPTOM:

- ABS does not operate.

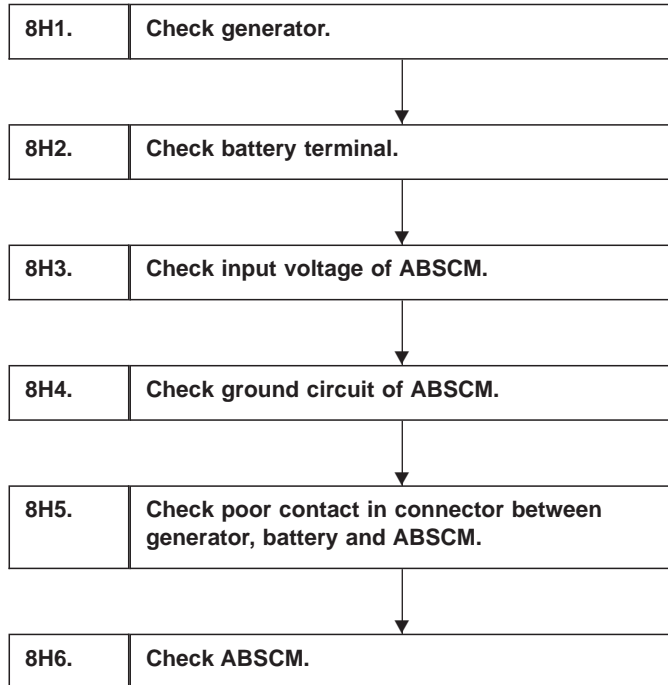

WIRING DIAGRAM:

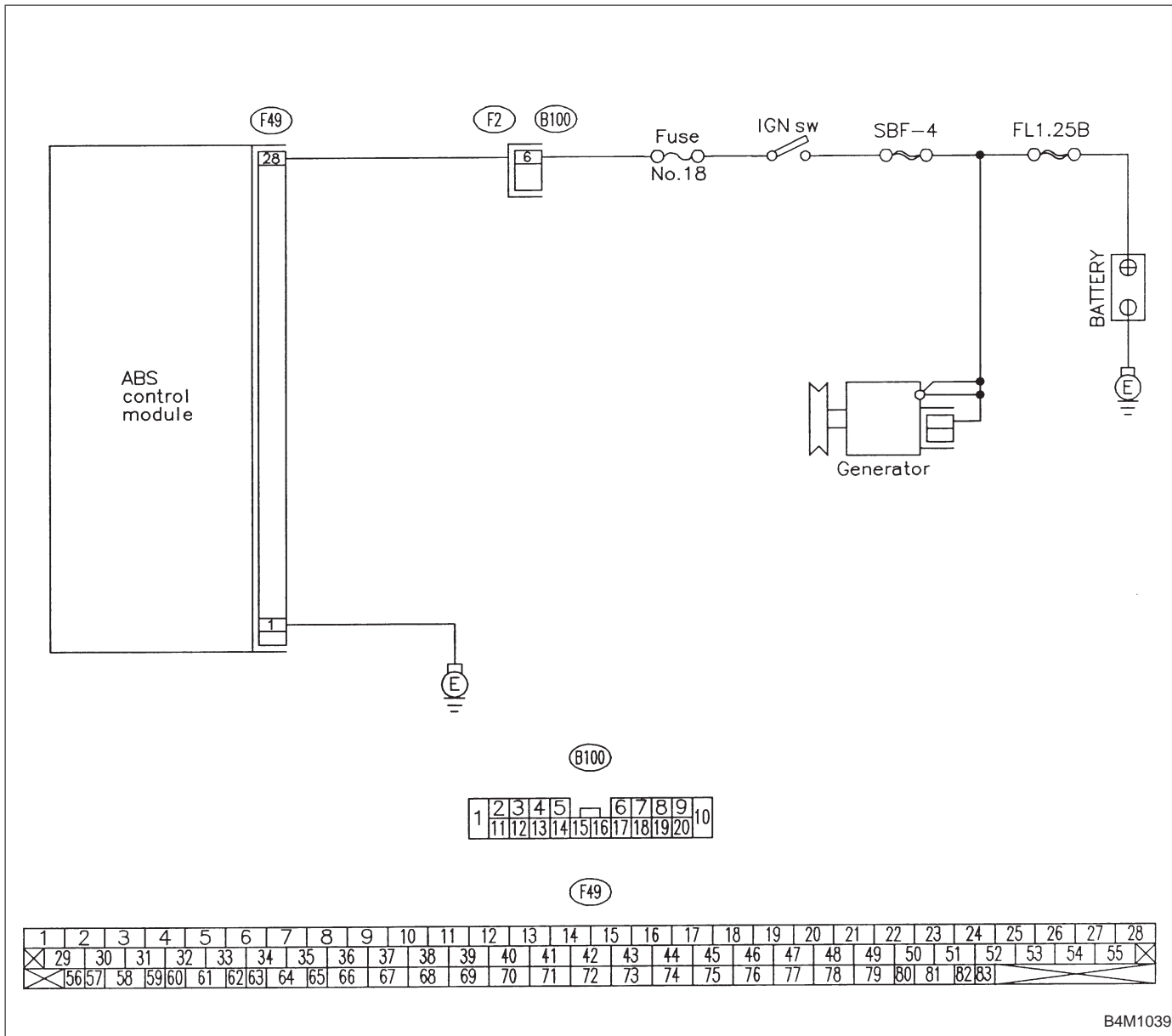

B4M1039

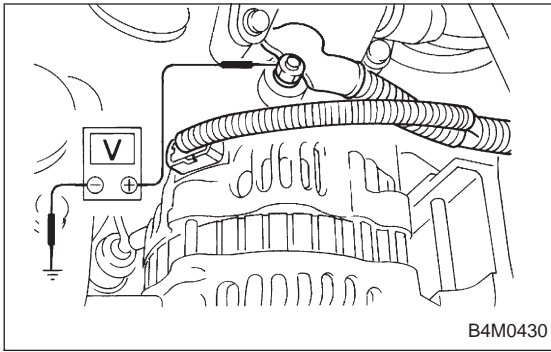

B4M0430

8H1 CHECK GENERATOR.

- 1) Start engine.
- 2) Idling after warm-up.
- 3) Measure voltage between generator B terminal and chassis ground.

CHECK : *Terminal Generator B terminal — Chassis ground*
Is voltage 10 — 15 V?

YES : Go to step 8H2.

NO : Repair generator.

8H2 CHECK BATTERY TERMINAL.

Turn ignition switch to OFF.

CHECK : *Are the positive and negative battery terminals tightly clamped?*

YES : Go to step 8H3.

NO : Tighten the clamp of terminal.

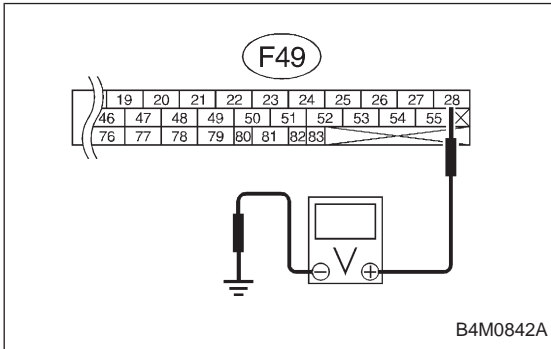

B4M0842A

8H3 CHECK INPUT VOLTAGE OF ABSCM.

- 1) Disconnect connector from ABSCM.
- 2) Run the engine at idle.
- 3) Measure voltage between ABSCM connector and chassis ground.

CHECK : *Connector & terminal (F49) No. 28 (+) — Chassis ground (-)*
Is voltage 10 — 15 V?

YES : Go to step 8H4.

NO : Repair harness connector between battery, ignition switch and ABSCM.

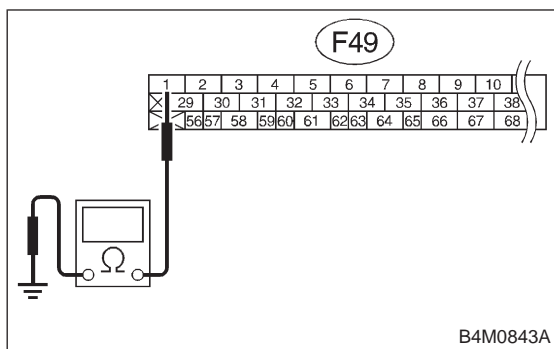
**8H4 CHECK GROUND CIRCUIT OF ABSCM.**

- 1) Turn ignition switch to OFF.
- 2) Measure resistance between ABSCM connector and chassis ground.

CHECK : **Connector & terminal (F49) No. 1 — Chassis ground**
Is resistance less than 0.5 Ω?

YES : Go to step 8H5.

NO : Repair ABSCM ground harness.

8H5 CHECK POOR CONTACT IN CONNECTOR BETWEEN GENERATOR, BATTERY AND ABSCM.

CHECK : **Is there poor contact in connectors between generator, battery and ABSCM?**

YES : Repair connector.

NO : Go to step 8H6.

8H6 CHECK ABSCM.

- 1) Connect all connectors.
- 2) Erase the memory.
- 3) Perform inspection mode.
- 4) Read out the trouble code.

CHECK : **Is the same trouble code as in the current diagnosis still being output?**

YES : Replace ABSCM.

NO : Go to next **CHECK** .

CHECK : **Are other trouble codes being output?**

YES : Proceed with the diagnosis corresponding to the trouble code.

NO : A temporary poor contact.

**I: TROUBLE CODE 44
— A COMBINATION OF AT CONTROL
ABNORMALS —****DIAGNOSIS:**

- Combination of AT control faults

TROUBLE SYMPTOM:

- ABS does not operate.

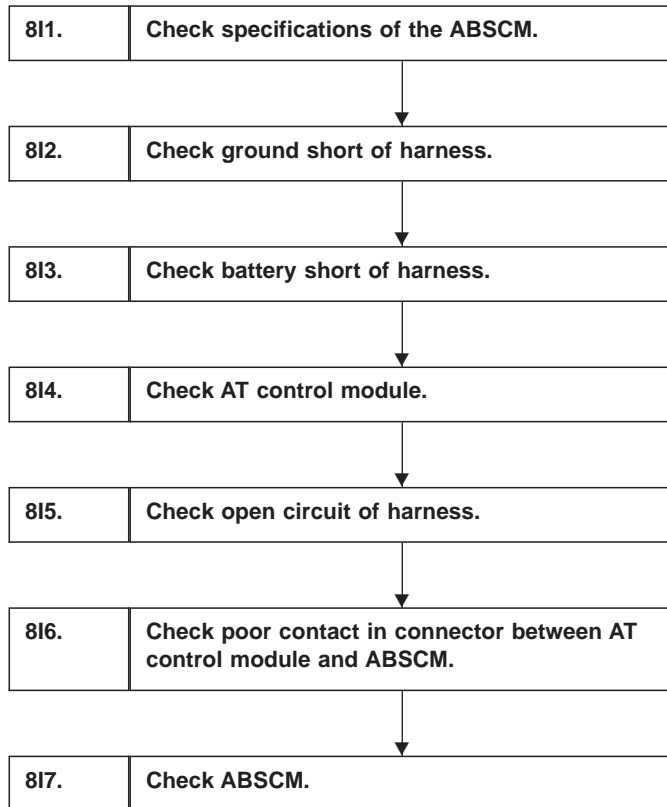

WIRING DIAGRAM:

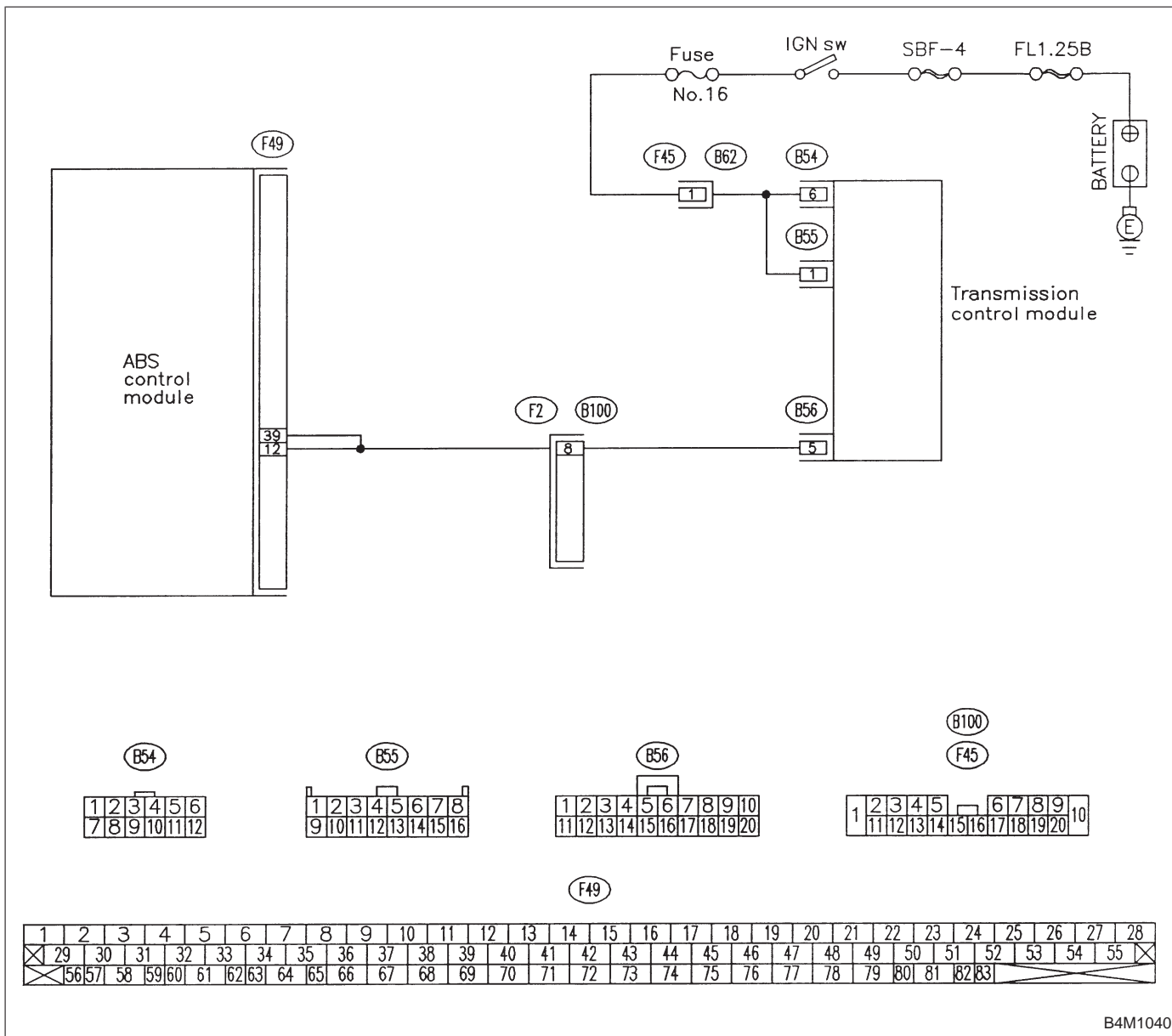

B4M1040

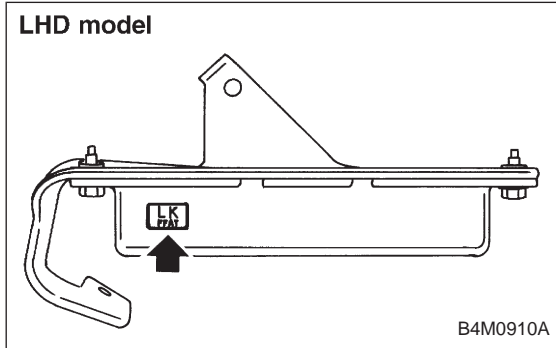

811	CHECK SPECIFICATIONS OF THE ABSCM.
Check specifications of the plate attached to the ABSCM.	
CHECK	: Is an ABSCM for AT model installed on a MT model?
YES	: Replace ABSCM.
NO	: Go to step 812.

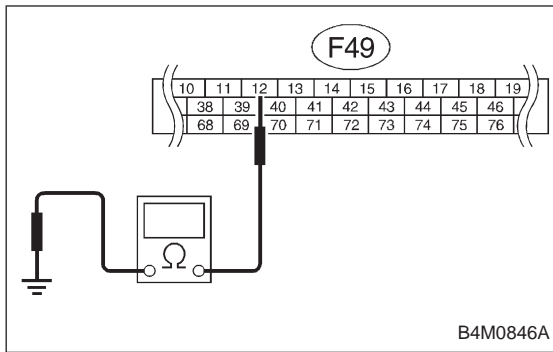

8I2 CHECK GROUND SHORT OF HARNESS.

- 1) Turn ignition switch to OFF.
- 2) Disconnect two connectors from AT control module.
- 3) Disconnect connector from ABSCM.
- 4) Measure resistance between ABSCM connector and chassis ground.

CHECK : **Connector & terminal (F49) No. 12 — Chassis ground**
Is resistance more than 1 MΩ?

YES : Go to step 8I3.

NO : Repair harness between AT control module and ABSCM.

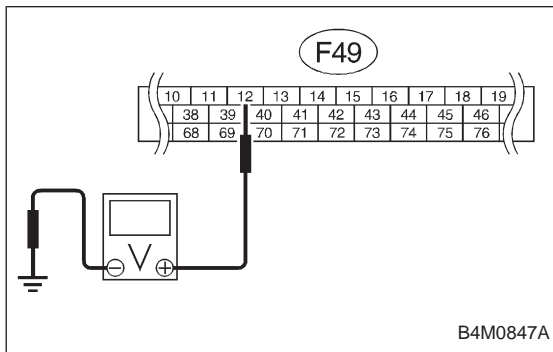

8I3 CHECK BATTERY SHORT OF HARNESS.

- 1) Turn ignition switch to ON.
- 2) Measure voltage between ABSCM connector and chassis ground.

CHECK : **Connector & terminal (F49) No. 12 (+) — Chassis ground (-)**
Is voltage 0 V?

YES : Go to next step.

NO : Repair harness between AT control module and ABSCM.

- 3) Turn ignition switch to OFF.
- 4) Measure voltage between ABSCM connector and chassis ground.

CHECK : **Connector & terminal (F49) No. 12 (+) — Chassis ground (-)**
Is voltage 0 V?

YES : Go to step 8I4.

NO : Repair harness between AT control module and ABSCM.

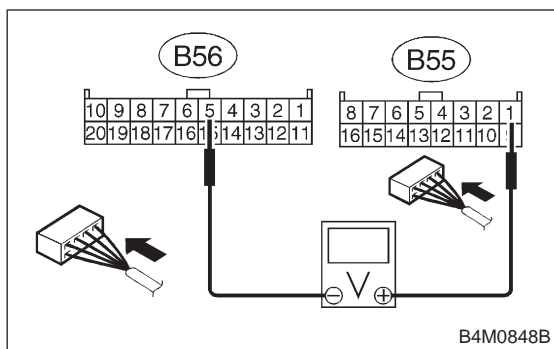
**814** CHECK AT CONTROL MODULE.

- 1) Connect all connectors to AT control module.
- 2) Turn ignition switch to ON.
- 3) Measure voltage between AT control module connector terminals.

CHECK : **Connector & terminal**
(B55) No. 1 (+) — (B56) No. 5 (-)
Is voltage 10 — 13 V?

YES : Go to step 815.

NO : Go to next step.

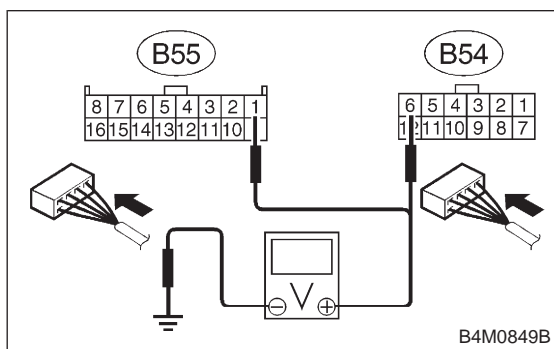

- 4) Measure voltage between AT control module connector and chassis ground.

CHECK : **Connector & terminal**
(B54) No. 6 (+) — Chassis ground (-)
(B55) No. 1 (+) — Chassis ground (-)
Is voltage 10 — 13 V?

YES : Replace AT control module.

NO : Repair harness connector between battery, ignition switch and AT control module.

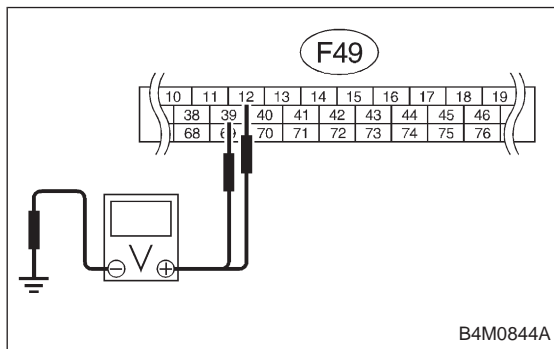
**815** CHECK OPEN CIRCUIT OF HARNESS.

Measure voltage between ABSCM connector and chassis ground.

CHECK : **Connector & terminal**
(F49) No. 12 (+) — Chassis ground (-)
(F49) No. 39 (+) — Chassis ground (-)
Is voltage 10 — 13 V?

YES : Go to step 816.

NO : Repair harness connector between AT control module and ABSCM.

816	CHECK POOR CONTACT IN CONNECTOR BETWEEN AT CONTROL MODULE AND ABSCM.
------------	---

CHECK : *Is there poor contact in connectors between AT control module and ABSCM?*

YES : Repair connector.

NO : Go to step **817**.

817	CHECK ABSCM.
------------	---------------------

1) Connect all connectors.

2) Erase the memory.

3) Perform inspection mode.

4) Read out the trouble code.

CHECK : *Is the same trouble code as in the current diagnosis still being output?*

YES : Replace ABSCM.

NO : Go to next **CHECK** .

CHECK : *Are other trouble codes being output?*

YES : Proceed with the diagnosis corresponding to the trouble code.

NO : A temporary poor contact.

**J: TROUBLE CODE 46
— ABNORMAL G SENSOR POWER SUPPLY
VOLTAGE —****DIAGNOSIS:**

- Faulty G sensor power supply voltage

TROUBLE SYMPTOM:

- ABS does not operate.

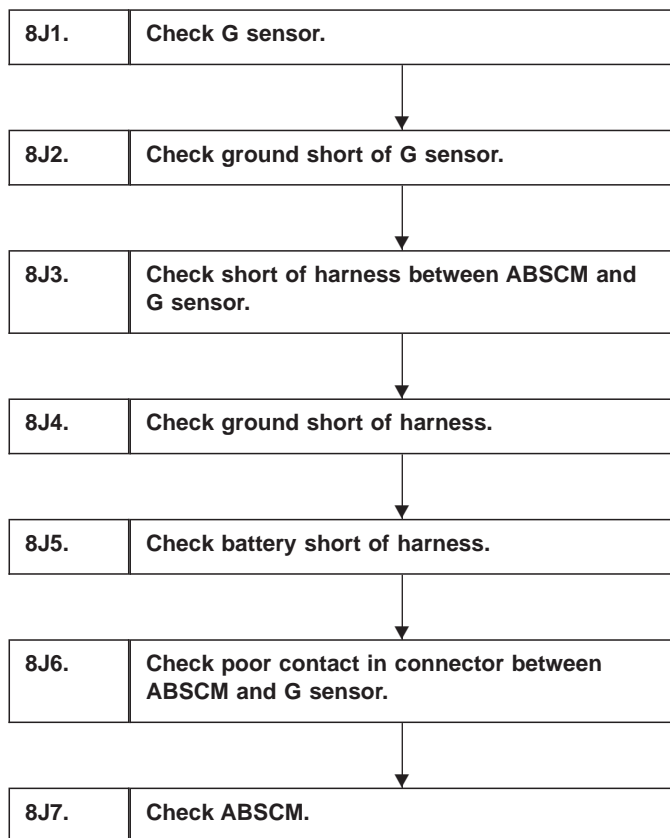

WIRING DIAGRAM:

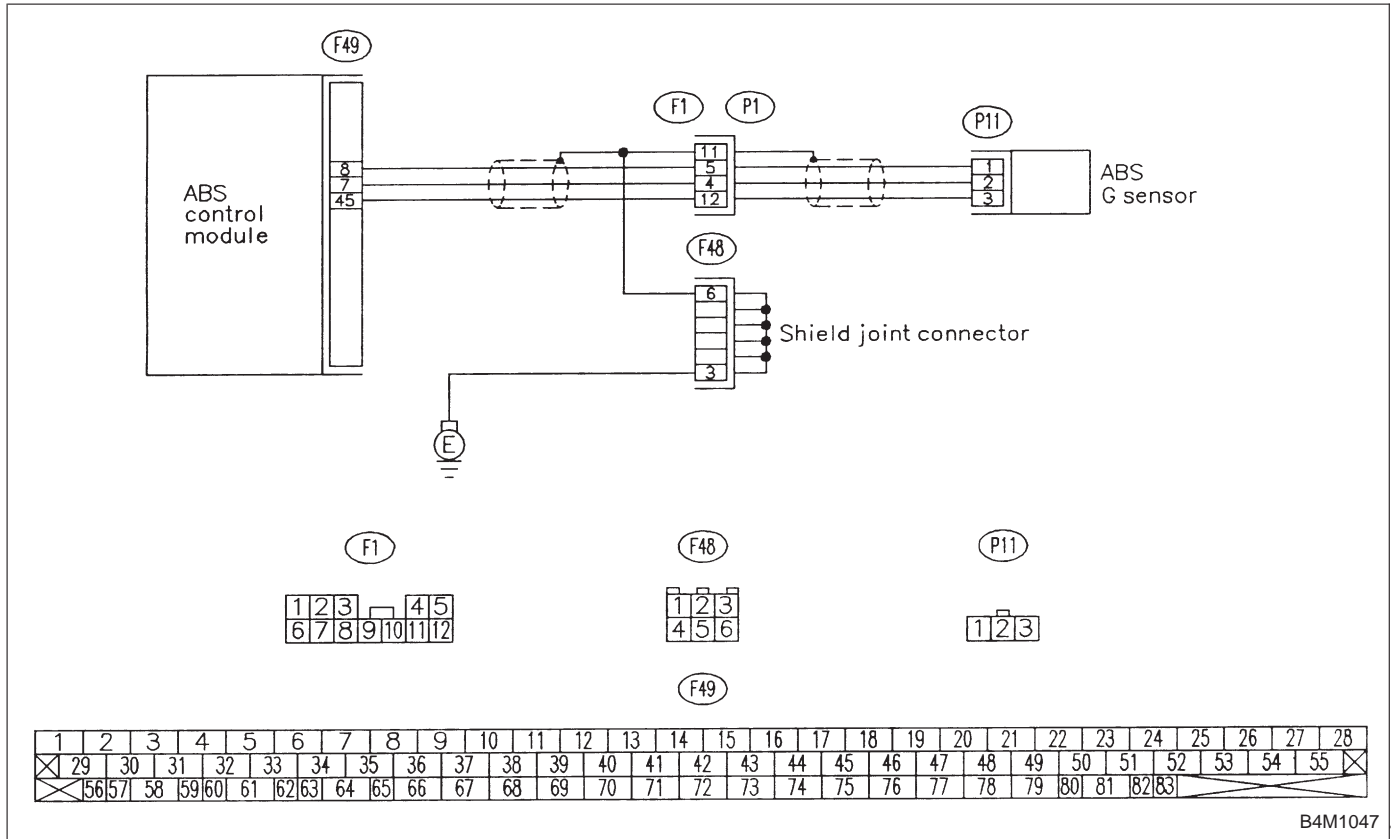

B4M1047

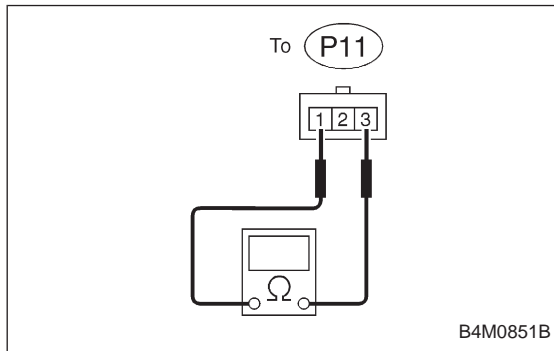

8J1 CHECK G SENSOR.

- 1) Turn ignition switch to OFF.
- 2) Remove console box.
- 3) Disconnect connector from G sensor.
- 4) Measure resistance of G sensor.

CHECK : **Connector & terminal**
To (P11) No. 1 — No. 3
Is resistance 50±8 kΩ?

YES : Go to step 8J2.

NO : Replace G sensor.

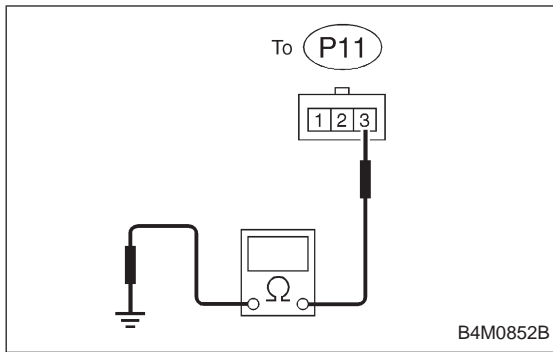

8J2 CHECK GROUND SHORT OF G SENSOR.

Measure resistance between G sensor and bracket.

- CHECK** : **Connector & terminal To (P11) No. 3 — Bracket**
Is resistance more than 1 MΩ?
- YES** : Go to step 8J3.
- NO** : Replace G sensor.

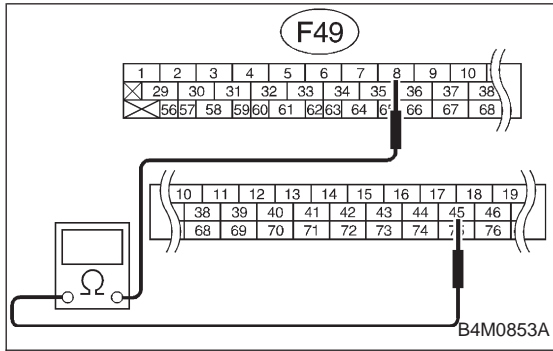

8J3 CHECK SHORT OF HARNESS BETWEEN ABSCM AND G SENSOR.

- 1) Disconnect connector from ABSCM.
- 2) Measure resistance between ABSCM connector terminals.

- CHECK** : **Connector & terminal (F49) No. 45 — No. 8**
Is resistance more than 1 MΩ?
- YES** : Go to step 8J4.
- NO** : Repair harness between ABSCM and G sensor.

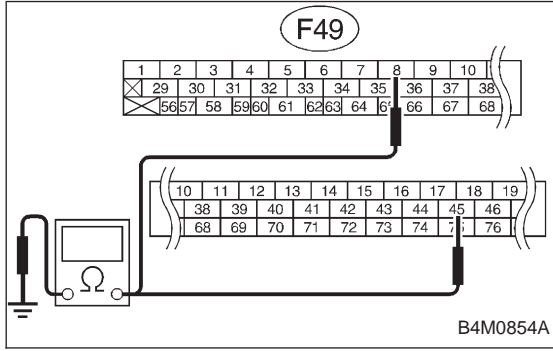

8J4 CHECK GROUND SHORT OF HARNESS.

Measure resistance between ABSCM connector and chassis ground.

- CHECK** : **Connector & terminal (F49) No. 8 — Chassis ground**
(F49) No. 45 — Chassis ground
Is resistance more than 1 MΩ?
- YES** : Go to step 8J5.
- NO** : Repair harness between ABSCM and G sensor.

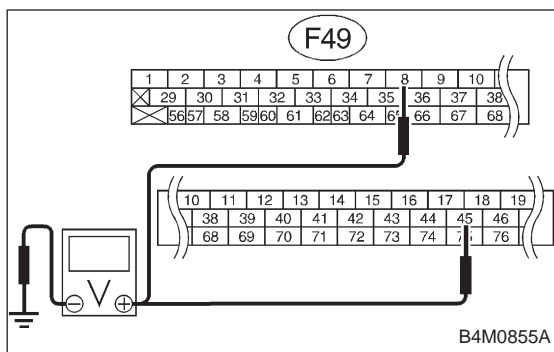
**8J5 CHECK BATTERY SHORT OF HARNESS.**

- 1) Turn ignition switch to ON.
- 2) Measure voltage between ABSCM connector and chassis ground.

CHECK : **Connector & terminal**
(F49) No. 8 (+) — Chassis ground (-)
(F49) No. 45 (+) — Chassis ground (-)
Is voltage 0 V?

YES : Go to next step.

NO : Repair harness between ABSCM and G sensor.

- 3) Turn ignition switch to OFF.
- 4) Measure voltage between ABSCM and chassis ground.

CHECK : **Connector & terminal**
(F49) No. 8 (+) — Chassis ground (-)
(F49) No. 45 (+) — Chassis ground (-)
Is voltage 0 V?

YES : Go to step **8J6**.

NO : Repair harness between ABSCM and chassis ground.

8J6 CHECK POOR CONTACT IN CONNECTOR BETWEEN ABSCM AND G SENSOR.

CHECK : **Is there poor contact in connectors between ABSCM and G sensor?**

YES : Repair connector.

NO : Go to step **8J7**.

8J7 CHECK ABSCM.

- 1) Connect all connectors.
- 2) Erase the memory.
- 3) Perform inspection mode.
- 4) Read out the trouble code.

CHECK : **Is the same trouble code as in the current diagnosis still being output?**

YES : Replace ABSCM.

NO : Go to next **CHECK** .

CHECK : **Are other trouble codes being output?**

YES : Proceed with the diagnosis corresponding to the trouble code.

NO : A temporary poor contact.

K: TROUBLE CODE 51 — ABNORMAL VALVE RELAY —

DIAGNOSIS:

- Faulty valve relay

TROUBLE SYMPTOM:

- ABS does not operate.

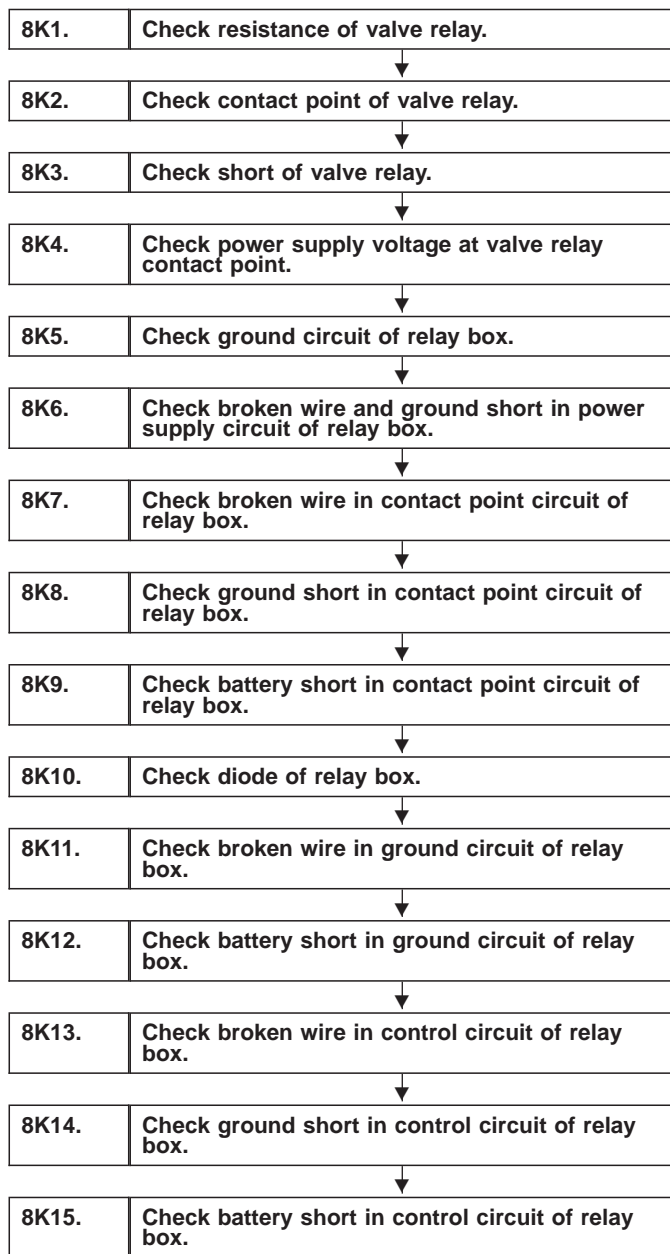

Continues to next page.

From the former page.

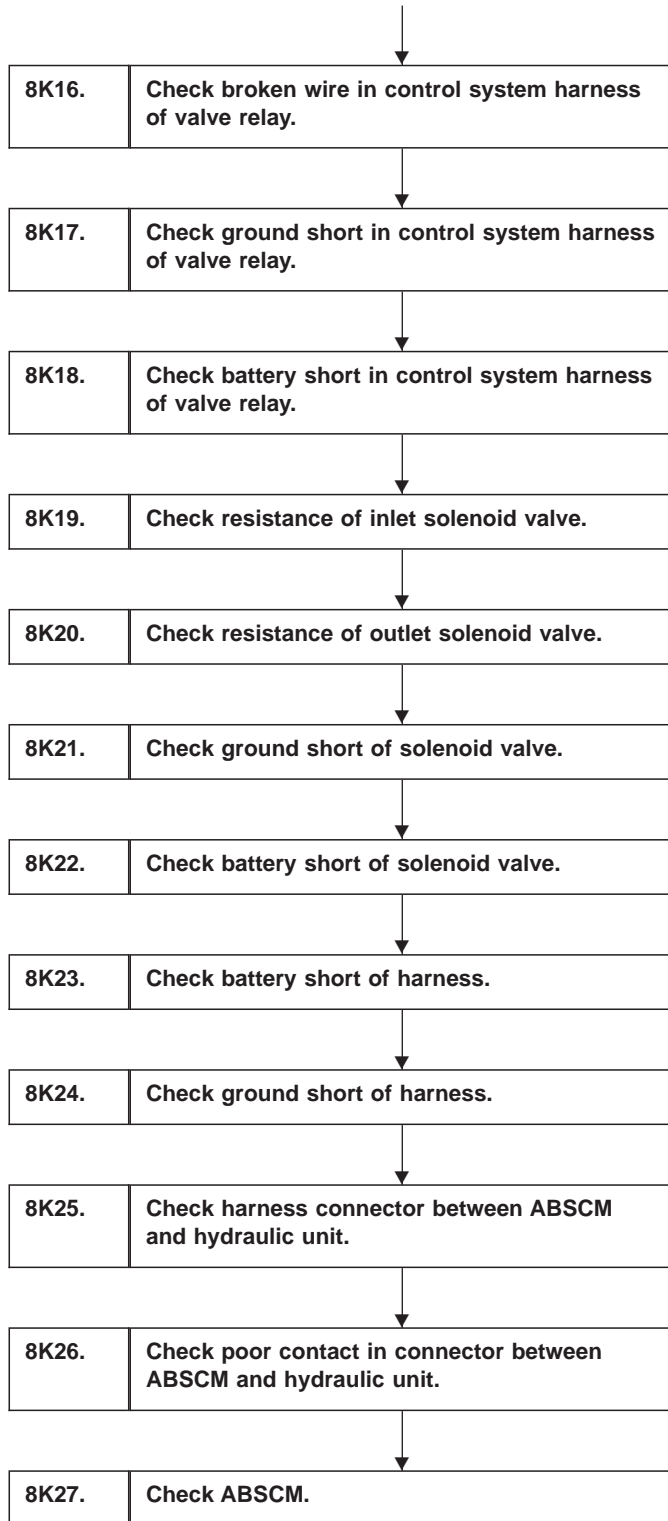

WIRING DIAGRAM:

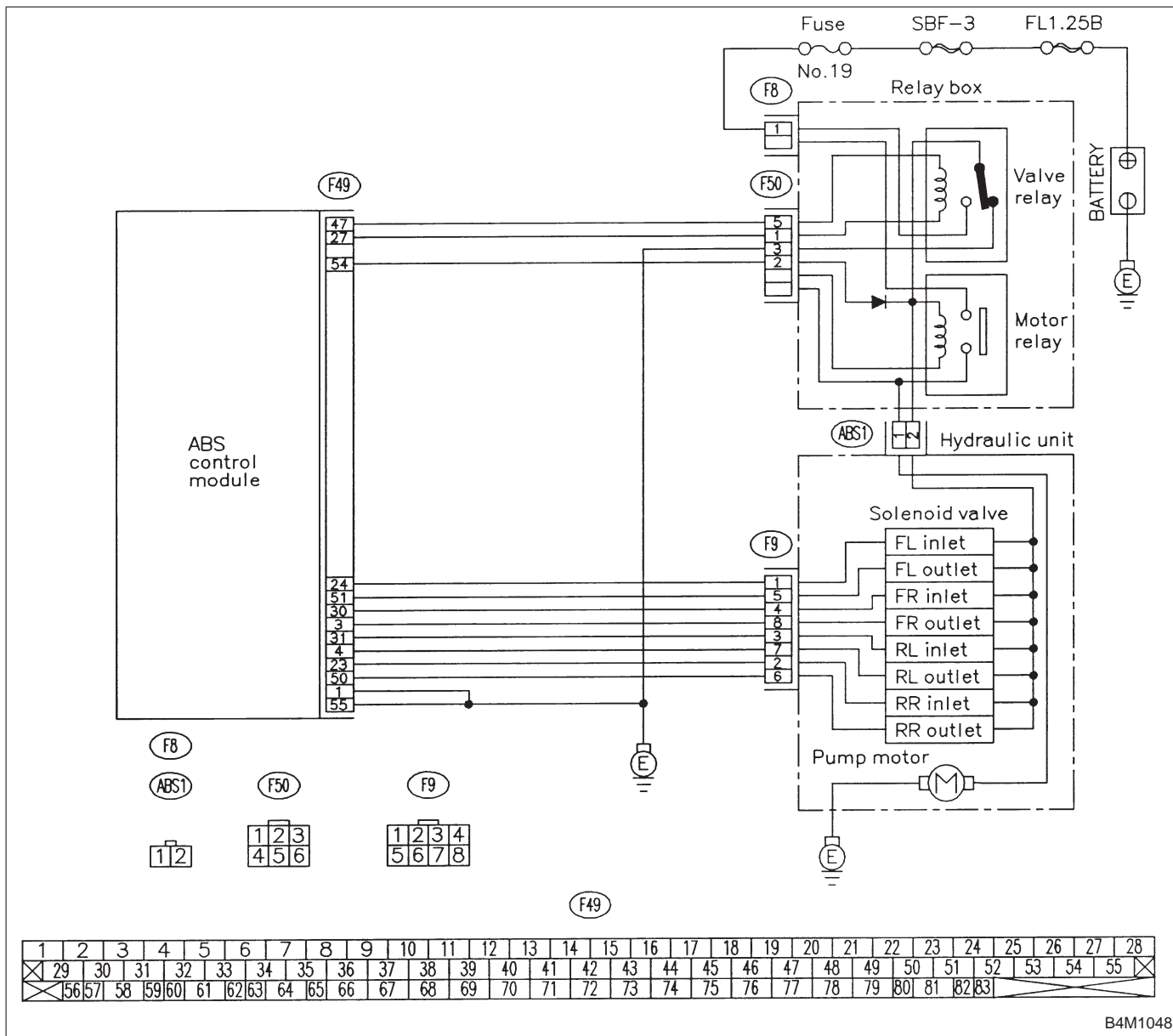

B4M1048

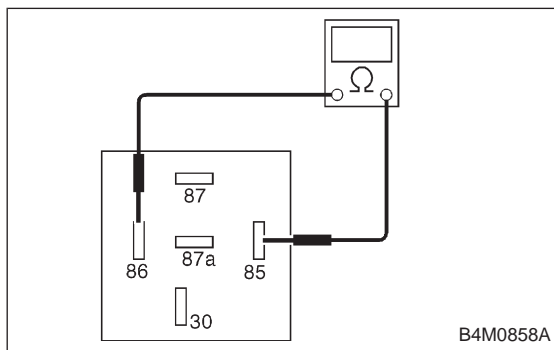

B4M0858A

8K1 CHECK RESISTANCE OF VALVE RELAY.

- 1) Turn ignition switch to OFF.
- 2) Remove valve relay from relay box.
- 3) Measure resistance between valve relay terminals.

CHECK : **Terminals**
No. 85 — No. 86
Is resistance 103±10 Ω?

YES : Go to step **8K2**.

NO : Replace valve relay.

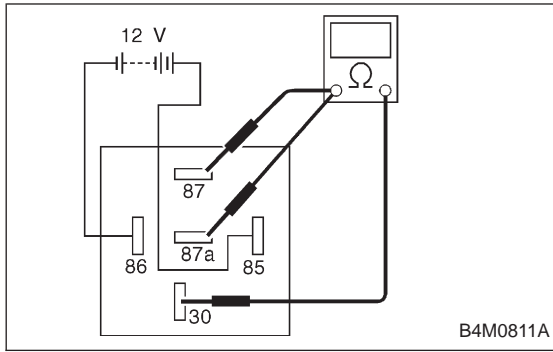

8K2

CHECK CONTACT POINT OF VALVE RELAY.

- 1) Connect battery to valve relay terminals No. 85 and No. 86.
- 2) Measure resistance between valve relay terminals.

CHECK : **Terminals**
No. 30 — No. 87
Is resistance less than 0.5 Ω?

YES : Go to next **CHECK** .

NO : Replace valve relay.

CHECK : **Terminals**
No. 30 — No. 87a
Is resistance more than 1 MΩ?

YES : Go to next step.

NO : Replace valve relay.

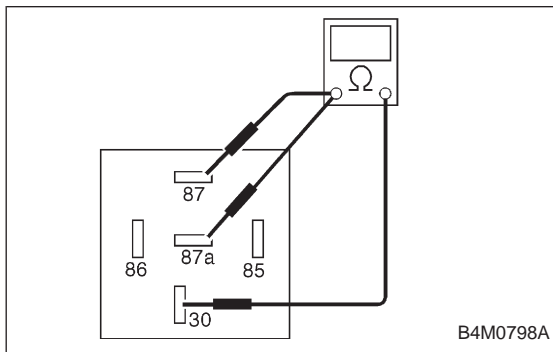

- 3) Disconnect battery from valve relay terminals.
- 4) Measure resistance between valve relay terminals.

CHECK : **Terminals**
No. 30 — No. 87
Is resistance more than 1 MΩ?

YES : Go to next **CHECK** .

NO : Replace valve relay.

CHECK : **Terminals**
No. 30 — No. 87a
Is resistance less than 0.5 Ω?

YES : Go to step 8K3.

NO : Replace valve relay.

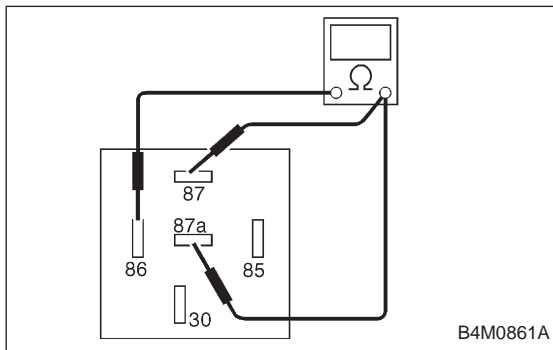

8K3

CHECK SHORT OF VALVE RELAY.

Measure resistance between valve relay terminals.

CHECK : **Terminals**
No. 86 — No. 87
No. 86 — No. 87a
Is resistance more than 1 MΩ?

YES : Go to step 8K4.

NO : Replace valve relay.

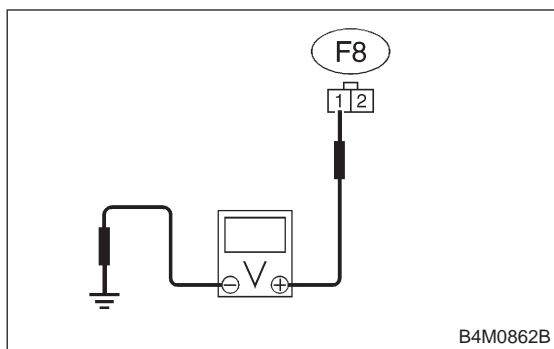
**8K4****CHECK POWER SUPPLY VOLTAGE AT VALVE RELAY CONTACT POINT.**

- 1) Disconnect connector (F8) from relay box.
- 2) Measure voltage between relay box connector and chassis ground.

CHECK : **Connector & terminal (F8) No. 1 (+) — Chassis ground (-)**
Is voltage 10 — 13 V?

YES : Go to step **8K5**.

NO : Repair harness connector between battery and relay box. Check fuse No. 19.

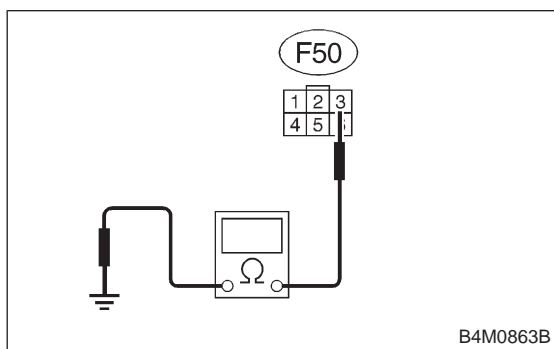
**8K5****CHECK GROUND CIRCUIT OF RELAY BOX.**

- 1) Disconnect connector (F50) from relay box.
- 2) Measure resistance between relay box connector and chassis ground.

CHECK : **Connector & terminal (F50) No. 3 — Chassis ground**
Is resistance less than 0.5 Ω?

YES : Go to step **8K6**.

NO : Repair relay box ground harness.

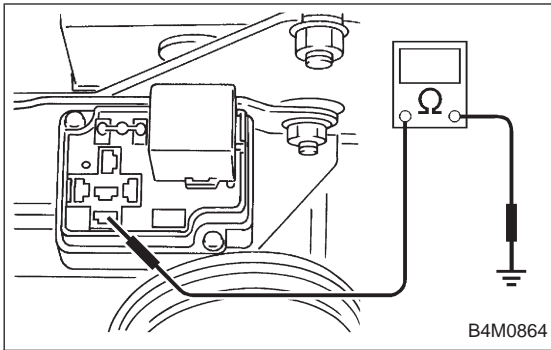
**8K6****CHECK BROKEN WIRE AND GROUND SHORT IN POWER SUPPLY CIRCUIT OF RELAY BOX.**

- 1) Disconnect connector (ABS1) from hydraulic unit.
- 2) Connect connector (F8) to relay box.
- 3) Measure voltage of relay box.

CHECK : **Connector & terminal**
Valve relay installing point No. 87 — Chassis ground
Is voltage 10 — 13 V?

YES : Go to step **8K7**.

NO : Replace relay box. Check fuse No. 19.

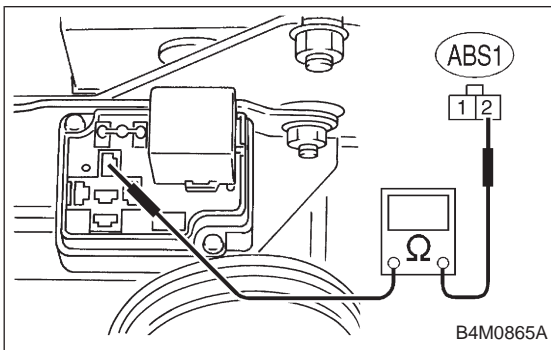
**8K7****CHECK BROKEN WIRE IN CONTACT POINT CIRCUIT OF RELAY BOX.**

Measure resistance between hydraulic unit connector and valve relay installing point.

CHECK : **Connector & terminal**
(ABS1) No. 2 — Valve relay installing point No. 30
Is resistance less than 0.5 Ω?

YES : Go to step **8K8**.

NO : Replace relay box.

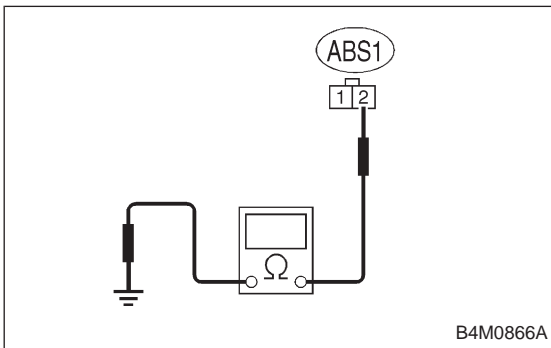
**8K8****CHECK GROUND SHORT IN CONTACT POINT CIRCUIT OF RELAY BOX.**

Measure resistance between hydraulic unit connector and chassis ground.

CHECK : **Connector & terminal**
(ABS1) No. 2 — Chassis ground
Is resistance more than 1 MΩ?

YES : Go to step **8K9**.

NO : Replace relay box. Check fuse SBF6.

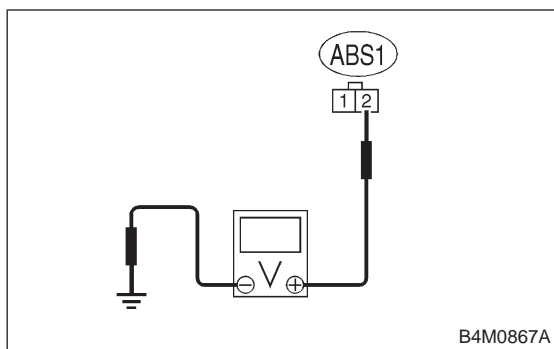
**8K9****CHECK BATTERY SHORT IN CONTACT POINT CIRCUIT OF RELAY BOX.**

- 1) Disconnect connector from ABSCM.
- 2) Turn ignition switch to ON.
- 3) Measure voltage between hydraulic unit connector and chassis ground.

CHECK : **Connector & terminal**
(ABS1) No. 2 (+) — Chassis ground (-)
Is voltage 0 V?

YES : Go to next step.

NO : Replace relay box. Check fuse No. 19 and SBF6.

- 4) Turn ignition switch to OFF.

- 5) Measure voltage between hydraulic unit connector and chassis ground.

CHECK : **Connector & terminal**
(ABS1) No. 2 (+) — Chassis ground (-)
Is voltage 0 V?

YES : Go to step **8K10**.

NO : Replace relay box. Check fuse No. 19 and SBF6.

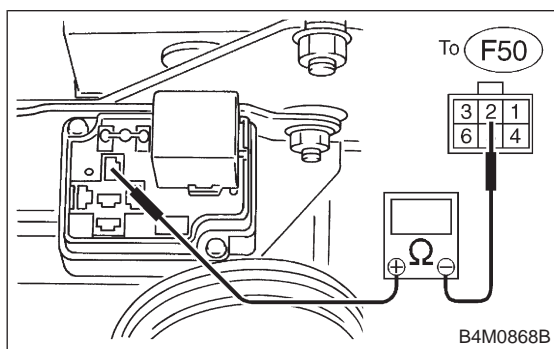
**8K10****CHECK DIODE OF RELAY BOX.**

Measure resistance between relay box connector and valve relay installing point.

CHECK : **Connector & terminal**
Valve relay installing point No. 30 (+) — To
(F50) No. 2 (-)
Is resistance more than 1 MΩ?

YES : Go to step **8K11**.

NO : Replace relay box.

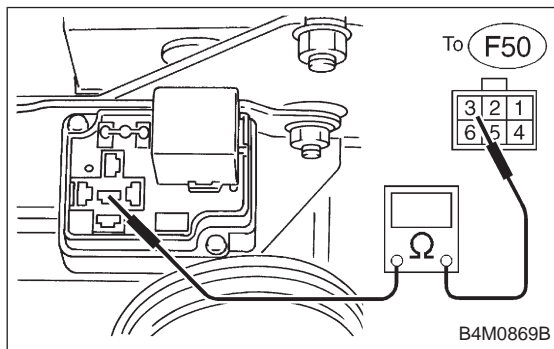
**8K11****CHECK BROKEN WIRE IN GROUND CIRCUIT OF RELAY BOX.**

Measure resistance between relay box connector and valve relay installing point.

CHECK : **Connector & terminal**
To (F50) No. 3 — Valve relay installing point
No. 87a
Is resistance less than 0.5 Ω?

YES : Go to step **8K12**.

NO : Replace relay box.

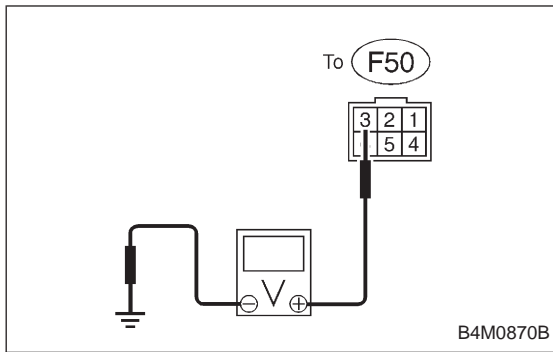

8K12

CHECK BATTERY SHORT IN GROUND CIRCUIT OF RELAY BOX.

- 1) Turn ignition switch to ON.
- 2) Measure voltage between relay box connector and chassis ground.

CHECK : *Connector & terminal To (F50) No. 3 (+) — Chassis ground (-) Is voltage 0 V?*

YES : Go to next step.

NO : Replace relay box and check all fuses.

- 3) Turn ignition switch to OFF.

- 4) Measure voltage between relay box connector and chassis ground.

CHECK : *Connector & terminal To (F50) No. 3 (+) — Chassis ground (-) Is voltage 0 V?*

YES : Go to step 8K13.

NO : Replace relay box and check all fuses.

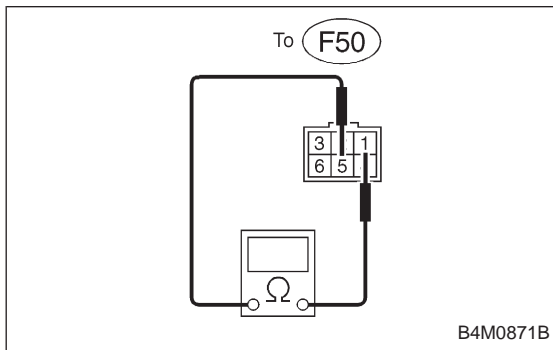

8K13

CHECK BROKEN WIRE IN CONTROL CIRCUIT OF RELAY BOX.

- 1) Install valve relay to relay box.
- 2) Measure resistance between relay box connector terminals.

CHECK : *Connector & terminal To (F50) No. 1 — No. 5 Is resistance 103±10 Ω?*

YES : Go to step 8K14.

NO : Replace relay box.

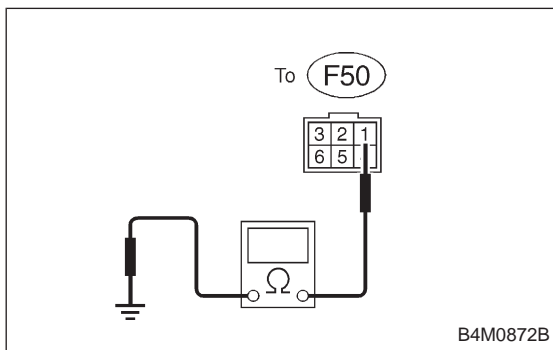

8K14

CHECK GROUND SHORT IN CONTROL CIRCUIT OF RELAY BOX.

- Measure resistance between relay box connector and chassis ground.

CHECK : *Connector & terminal To (F50) No. 1 — Chassis ground Is resistance more than 1 MΩ?*

YES : Go to step 8K15.

NO : Replace relay box and check all fuses.

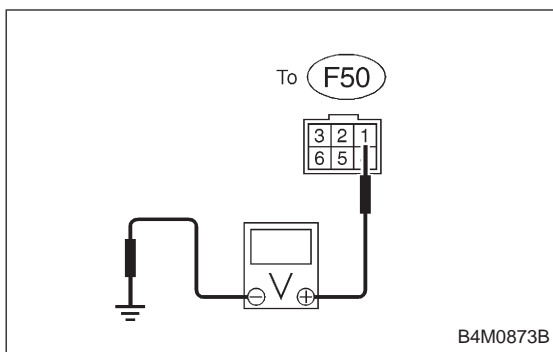

8K15 CHECK BATTERY SHORT IN CONTROL CIRCUIT OF RELAY BOX.

- 1) Turn ignition switch to ON.
- 2) Measure voltage between relay box connector and chassis ground.

CHECK : *Connector & terminal To (F50) No. 1 (+) — Chassis ground (-) Is voltage 0 V?*

YES : Go to next step.

NO : Replace relay box. Check fuse No. 19 and SBF45A.

- 3) Turn ignition switch to OFF.
- 4) Measure voltage between relay box connector and chassis ground.

CHECK : *Connector & terminal To (F50) No. 1 (+) — Chassis ground (-) Is voltage 0 V?*

YES : Go to step **8K16**.

NO : Replace relay box. Check fuse No. 19 and SBF45A.

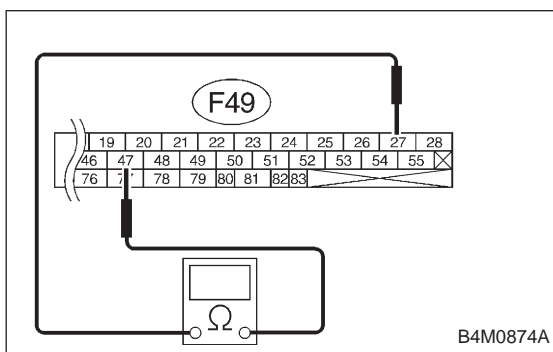

8K16 CHECK BROKEN WIRE IN CONTROL SYSTEM HARNESS OF VALVE RELAY.

- 1) Connect connector (F50) to relay box.
- 2) Measure resistance between ABSCM connector terminals.

CHECK : *Connector & terminal (F49) No. 27 — No. 47 Is resistance 103±10 Ω?*

YES : Go to step **8K17**.

NO : Repair harness between ABSCM and relay box. Check fuse No. 18.

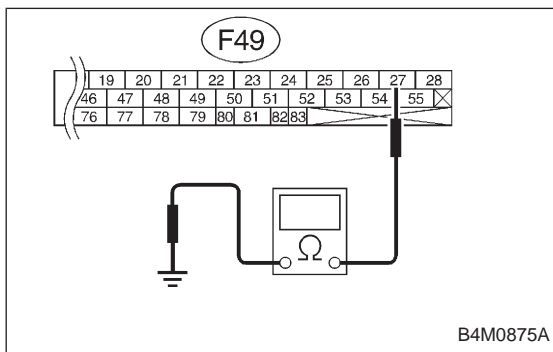

8K17 CHECK GROUND SHORT IN CONTROL SYSTEM HARNESS OF VALVE RELAY.

Measure resistance between ABSCM connector and chassis ground.

CHECK : *Connector & terminal (F49) No. 27 — Chassis ground Is resistance more than 1 MΩ?*

YES : Go to step **8K18**.

NO : Repair harness between ABSCM and relay box. Check fuse No. 18.

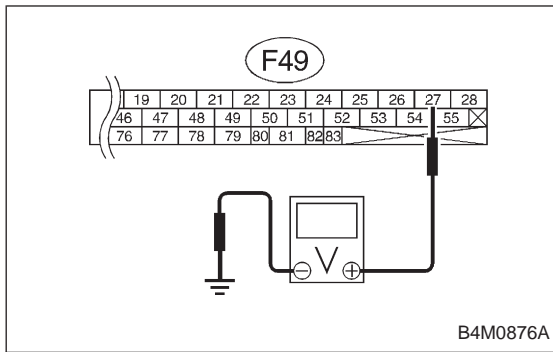

8K18

CHECK BATTERY SHORT IN CONTROL SYSTEM HARNESS OF VALVE RELAY.

- 1) Turn ignition switch to ON.
- 2) Measure voltage between ABSCM connector and chassis ground.

CHECK : **Connector & terminal (F49) No. 27 (+) — Chassis ground (-)**
Is voltage 0 V?

YES : Go to next step.

NO : Repair harness between ABSCM and relay box and check all fuses.

- 3) Turn ignition switch to OFF.
- 4) Measure voltage between ABSCM connector and chassis ground.

CHECK : **Connector & terminal (F49) No. 27 (+) — Chassis ground (-)**
Is voltage 0 V?

YES : Go to step 8K19.

NO : Repair harness between ABSCM and relay box and check all fuses.

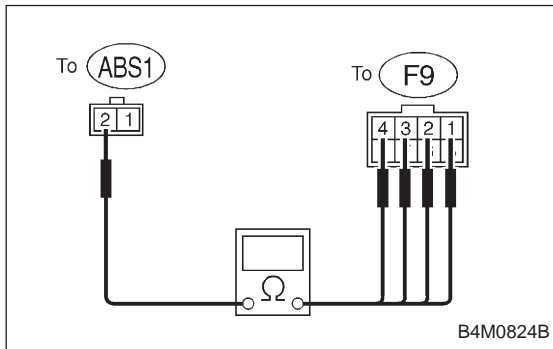

8K19

CHECK RESISTANCE OF INLET SOLENOID VALVE.

- 1) Disconnect connector from hydraulic unit.
- 2) Measure resistance between hydraulic unit connector terminals.

CHECK : **Connector & terminal**
To (F9) No. 4 — to (ABS1) No. 2
To (F9) No. 1 — to (ABS1) No. 2
To (F9) No. 2 — to (ABS1) No. 2
To (F9) No. 3 — to (ABS1) No. 2
Is resistance $8.5 \pm 0.7 \Omega$?

YES : Go to step 8K20.

NO : Replace hydraulic unit.

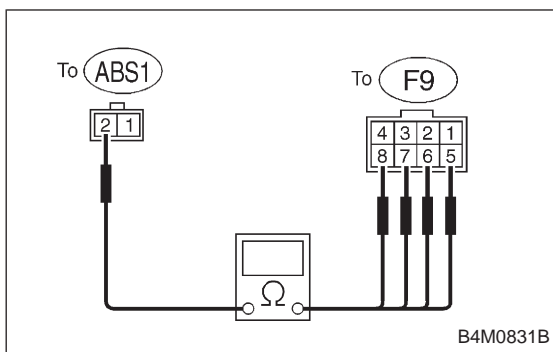

8K20 CHECK RESISTANCE OF OUTLET SOLENOID VALVE.

Measure resistance between hydraulic unit connector terminals.

- CHECK** : **Connector & terminal**
 To (F9) No. 8 — to (ABS1) No. 2
 To (F9) No. 5 — to (ABS1) No. 2
 To (F9) No. 6 — to (ABS1) No. 2
 To (F9) No. 7 — to (ABS1) No. 2
Is resistance $4.3 \pm 0.5 \Omega$?

- YES** : Go to step **8K21**.
NO : Replace hydraulic unit.

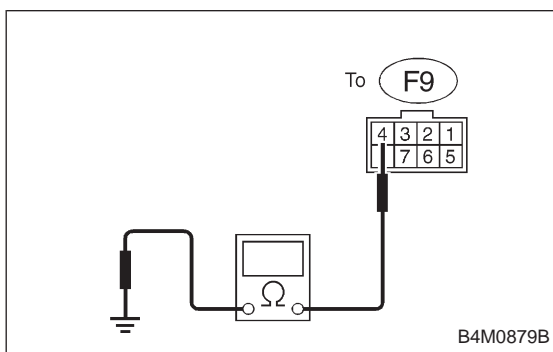

8K21 CHECK GROUND SHORT OF SOLENOID VALVE.

Measure resistance between hydraulic unit connector and chassis ground.

- CHECK** : **Connector & terminal**
 To (F9) No. 4 — Chassis ground
Is resistance more than $1 M\Omega$?

- YES** : Go to step **8K22**.
NO : Replace hydraulic unit and check all fuses.

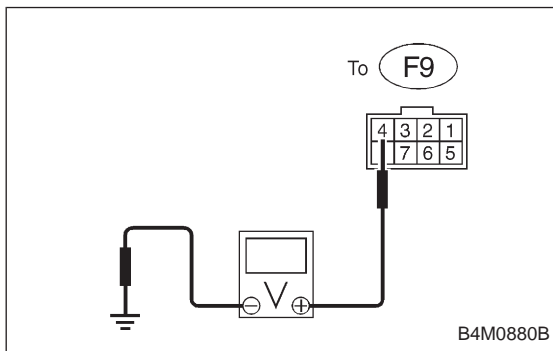

8K22 CHECK BATTERY SHORT OF SOLENOID VALVE.

- 1) Turn ignition switch to ON.
- 2) Measure voltage between hydraulic unit connector and chassis ground.

- CHECK** : **Connector & terminal**
 To (F9) No. 4 (+) — Chassis ground (-)
Is voltage $0 V$?

- YES** : Go to next step.
NO : Replace hydraulic unit and check all fuses.

- 3) Turn ignition switch to OFF.
- 4) Measure voltage between hydraulic unit connector and chassis ground.

- CHECK** : **Connector & terminal**
 To (F9) No. 4 (+) — Chassis ground (-)
Is voltage $0 V$?

- YES** : Go to step **8K23**.
NO : Replace hydraulic unit and check all fuses.

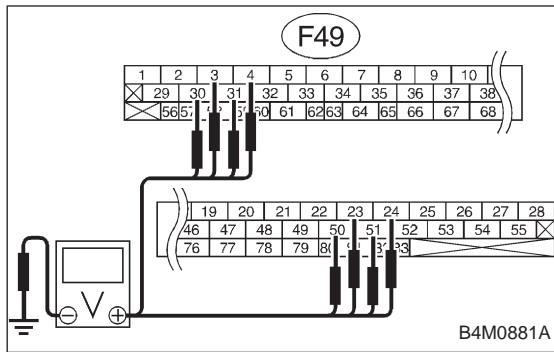
**8K23****CHECK BATTERY SHORT OF HARNESS.**

- 1) Disconnect connector from hydraulic unit.
- 2) Turn ignition switch to ON.
- 3) Measure voltage between ABSCM connector and chassis ground.

CHECK**: Connector & terminal****(F49) No. 30 (+) — Chassis ground (-)****(F49) No. 24 (+) — Chassis ground (-)****(F49) No. 23 (+) — Chassis ground (-)****(F49) No. 31 (+) — Chassis ground (-)****(F49) No. 3 (+) — Chassis ground (-)****(F49) No. 51 (+) — Chassis ground (-)****(F49) No. 50 (+) — Chassis ground (-)****(F49) No. 4 (+) — Chassis ground (-)****Is voltage 0 V?****YES**

: Go to next step.

NO

: Repair harness between hydraulic unit and ABSCM and check all fuses.

- 4) Turn ignition switch to OFF.
- 5) Measure voltage between ABSCM connector and chassis ground.

CHECK**: Connector & terminal****(F49) No. 30 (+) — Chassis ground (-)****(F49) No. 24 (+) — Chassis ground (-)****(F49) No. 23 (+) — Chassis ground (-)****(F49) No. 31 (+) — Chassis ground (-)****(F49) No. 3 (+) — Chassis ground (-)****(F49) No. 51 (+) — Chassis ground (-)****(F49) No. 50 (+) — Chassis ground (-)****(F49) No. 4 (+) — Chassis ground (-)****Is voltage 0 V?****YES**

: Go to step 8K24.

NO

: Repair harness between hydraulic unit and ABSCM and check all fuses.

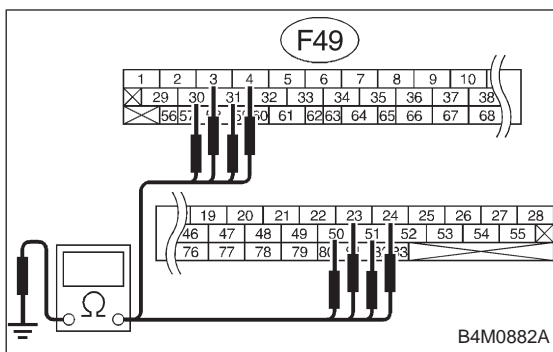

8K24 CHECK GROUND SHORT OF HARNESS.

Measure resistance between ABSCM connector and chassis ground.

- CHECK** : **Connector & terminal**
 (F49) No. 30 — Chassis ground
 (F49) No. 24 — Chassis ground
 (F49) No. 23 — Chassis ground
 (F49) No. 31 — Chassis ground
 (F49) No. 3 — Chassis ground
 (F49) No. 51 — Chassis ground
 (F49) No. 50 — Chassis ground
 (F49) No. 4 — Chassis ground
 Is resistance more than 1 MΩ?

- YES** : Go to step 8K25.
NO : Repair harness between hydraulic unit and ABSCM.

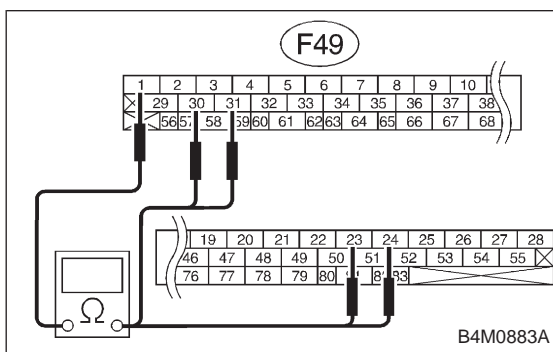

8K25 CHECK HARNESS CONNECTOR BETWEEN ABSCM AND HYDRAULIC UNIT.

- 1) Connect connector to hydraulic unit.
- 2) Measure resistance between ABSCM connector terminals.

- CHECK** : **Connector & terminal**
 (F49) No. 30 — No. 1
 (F49) No. 24 — No. 1
 (F49) No. 23 — No. 1
 (F49) No. 31 — No. 1
 Is resistance 9.0±0.7 Ω?

- YES** : Go to next **CHECK** .
NO : Repair harness connector between hydraulic unit and ABSCM.

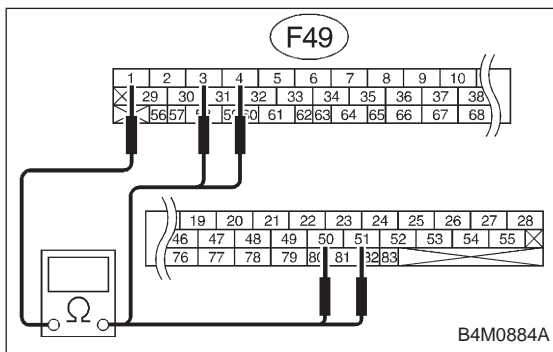

- CHECK** : **Connector & terminal**
 (F49) No. 3 — No. 1
 (F49) No. 51 — No. 1
 (F49) No. 50 — No. 1
 (F49) No. 4 — No. 1
 Is resistance 4.8±0.5 Ω?

- YES** : Go to step 8K26.
NO : Repair harness connector between hydraulic unit and ABSCM.

8K26	CHECK POOR CONTACT IN CONNECTOR BETWEEN ABSCM AND HYDRAULIC UNIT.
-------------	--

CHECK : *Is there poor contact in connector between ABSCM and hydraulic unit?*

YES : Repair connector.

NO : Go to step **8K27**.

8K27	CHECK ABSCM.
-------------	---------------------

1) Connect all connectors.

2) Erase the memory.

3) Perform inspection mode.

4) Read out the trouble code.

CHECK : *Is the same trouble code as in the current diagnosis still being output?*

YES : Replace ABSCM.

NO : Go to next **CHECK** .

CHECK : *Are other trouble codes being output?*

YES : Proceed with the diagnosis corresponding to the trouble code.

NO : A temporary poor contact.

**L: TROUBLE CODE 52
— ABNORMAL MOTOR AND/OR MOTOR
RELAY —**

DIAGNOSIS:

- Faulty motor
- Faulty motor relay
- Faulty harness connector

TROUBLE SYMPTOM:

- ABS does not operate.

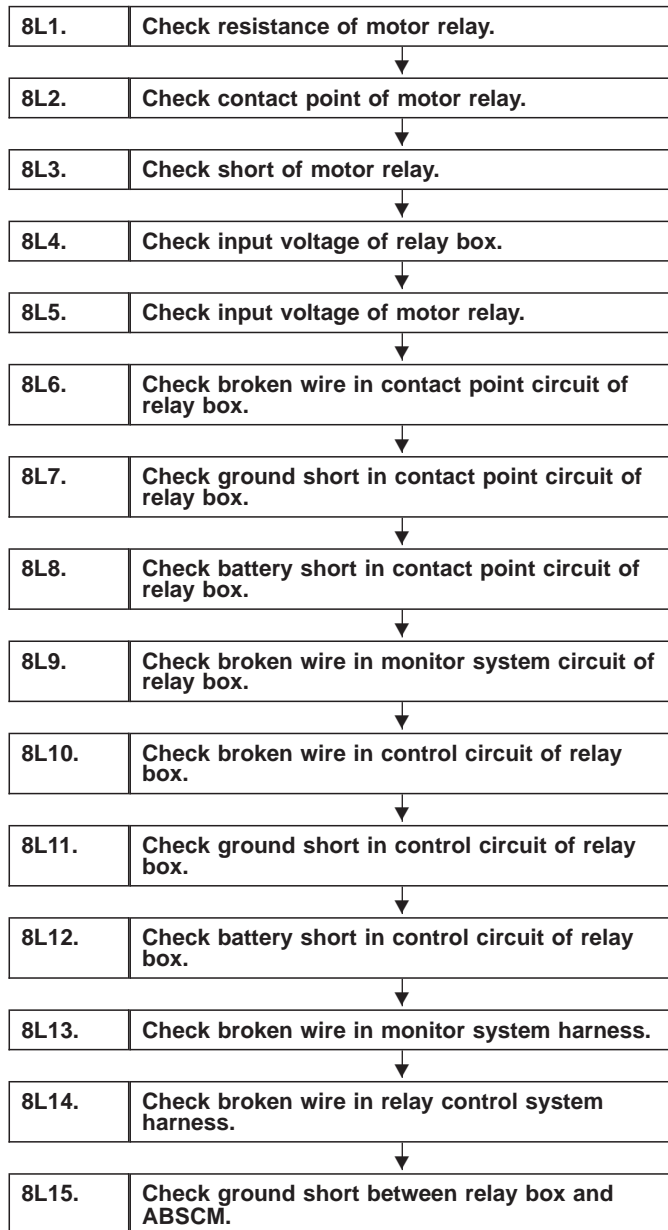

Continues to next page.

From the former page.

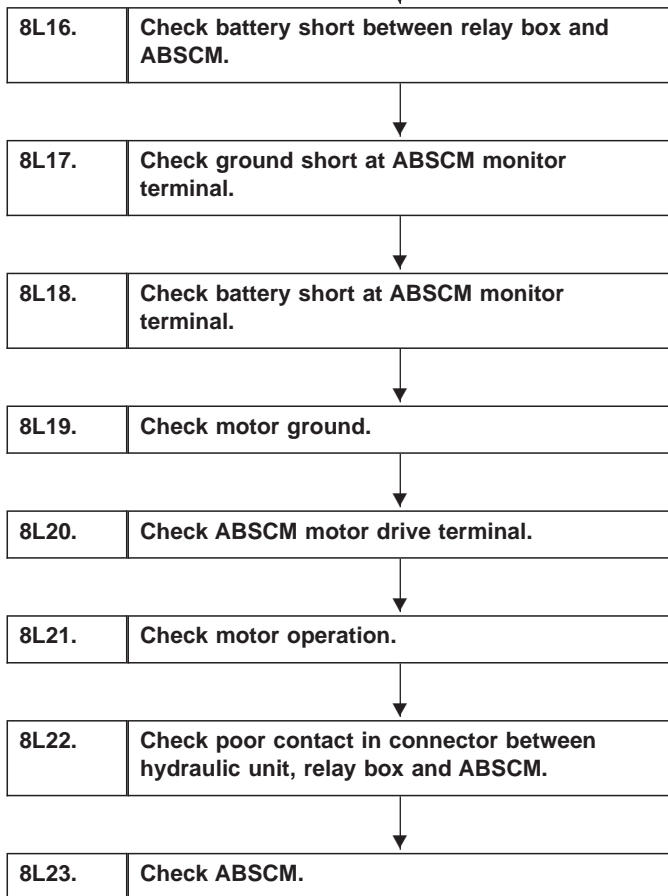

WIRING DIAGRAM:

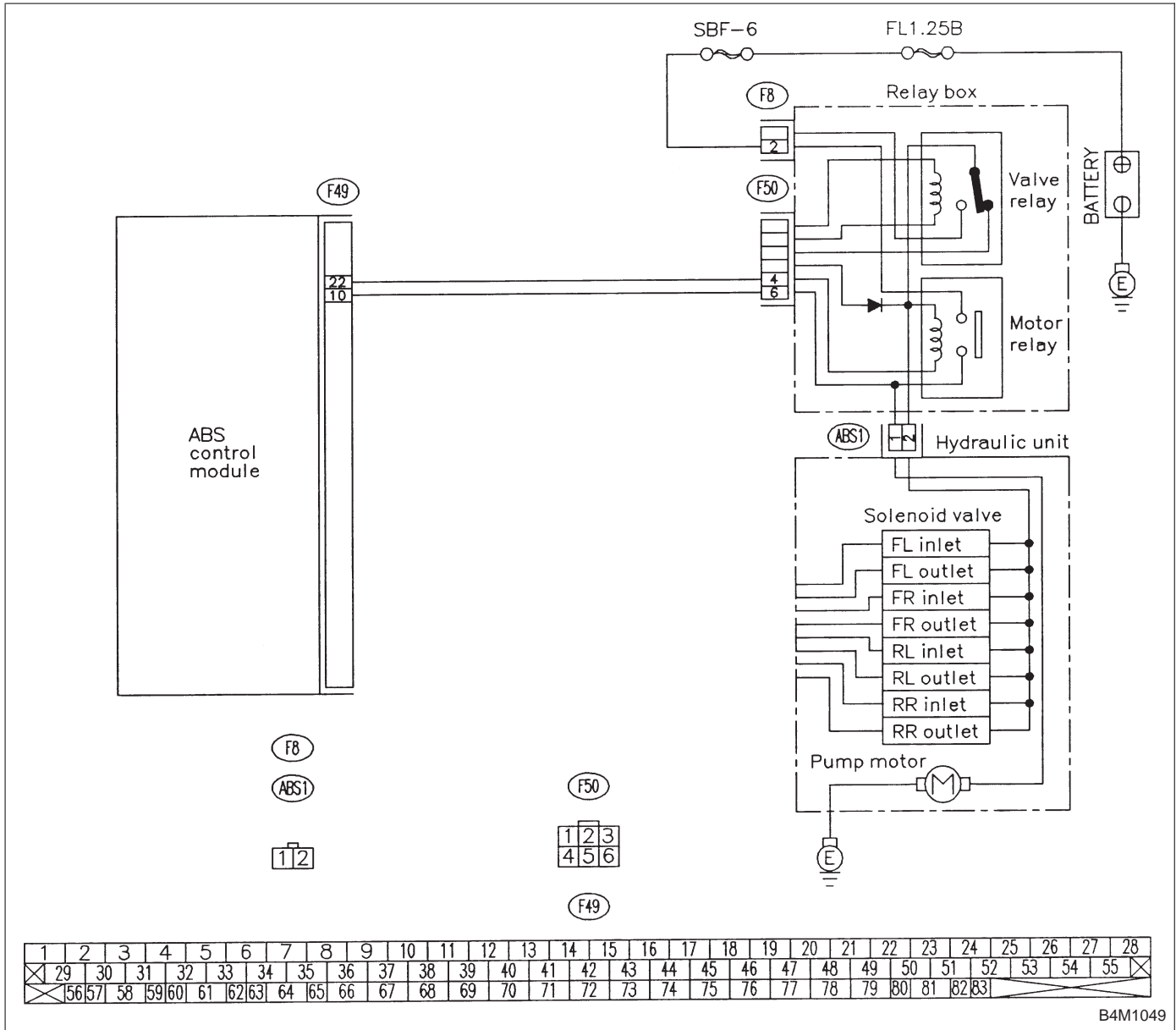

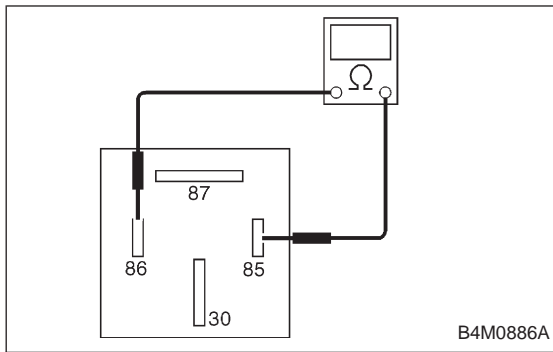

8L1 **CHECK RESISTANCE OF MOTOR RELAY.**

- 1) Turn ignition switch to OFF.
- 2) Remove motor relay from relay box.
- 3) Measure resistance between motor relay terminals.

CHECK : *Terminals*
No. 85 — No. 86
Is resistance $80 \pm 10 \Omega$?

YES : Go to step **8L2**.

NO : Replace motor relay.

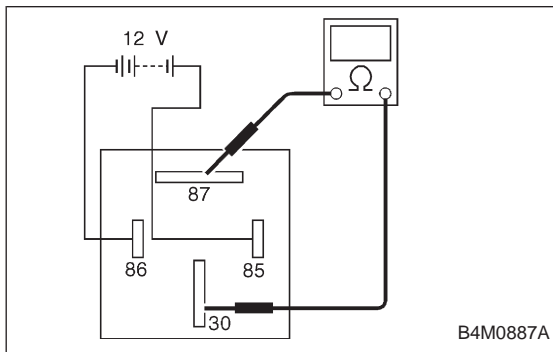

8L2 **CHECK CONTACT POINT OF MOTOR RELAY.**

- 1) Connect battery to motor relay terminals No. 85 and No. 86.
- 2) Measure resistance between motor relay terminals.

CHECK : *Terminals*
No. 30 — No. 87
Is resistance less than 0.5Ω ?

YES : Go to next step.

NO : Replace motor relay.

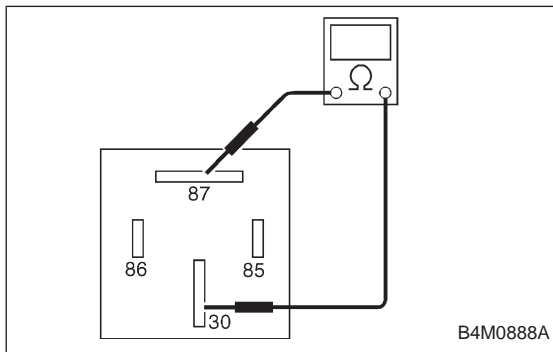

- 3) Disconnect battery from motor relay terminals.
- 4) Measure resistance between motor relay terminals.

CHECK : *Terminals*
No. 30 — No. 87
Is resistance more than $1 M\Omega$?

YES : Go to step **8L3**.

NO : Replace motor relay.

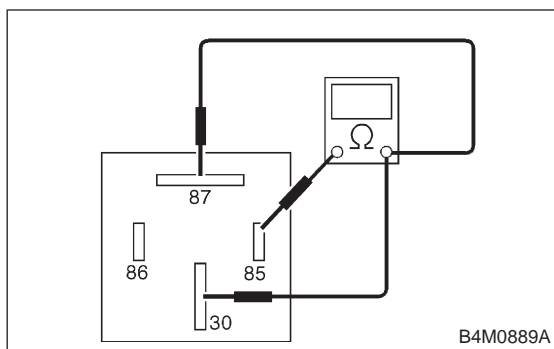
**8L3 CHECK SHORT OF MOTOR RELAY.**

Measure resistance between motor relay terminals.

CHECK : **Terminals**
No. 85 — No. 30
No. 85 — No. 87
Is resistance more than 1 MΩ?

YES : Go to step **8L4**.

NO : Replace motor relay.

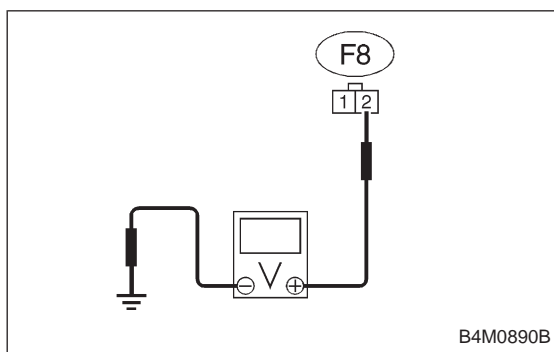
**8L4 CHECK INPUT VOLTAGE OF RELAY BOX.**

1) Disconnect connector (F8) from relay box.
 2) Measure voltage between relay box connector and chassis ground.

CHECK : **Connector & terminal**
(F8) No. 2 (+) — Chassis ground (-)
Is voltage 10 — 13 V?

YES : Go to step **8L5**.

NO : Repair harness connector between battery and relay box. Check fuse SBF6.

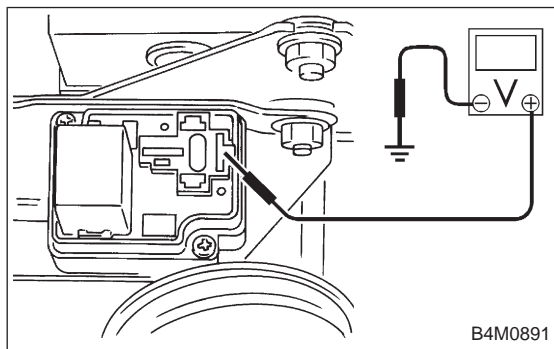
**8L5 CHECK INPUT VOLTAGE OF MOTOR RELAY.**

1) Connect connector (F8) to relay box.
 2) Measure voltage between relay box and chassis ground.

CHECK : **Connector & terminal**
Relay installing point No. 87 (+) — Chassis ground (-)
Is voltage more than 10 V?

YES : Go to step **8L6**.

NO : Replace relay box. Check fuse SBF6.

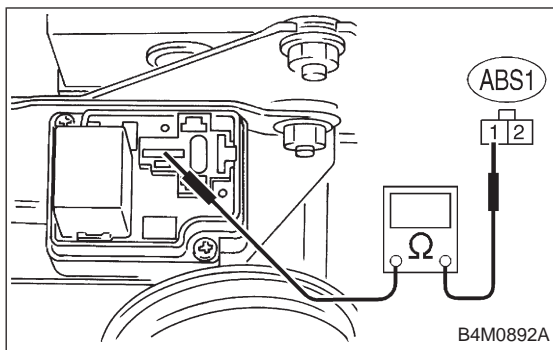
**8L6****CHECK BROKEN WIRE IN CONTACT POINT CIRCUIT OF RELAY BOX.**

- 1) Disconnect connector (ABS1) from hydraulic unit.
- 2) Measure resistance between hydraulic unit and motor relay installing portion.

CHECK : **Connector & terminal (ABS1) No. 1 — Motor relay installing portion No. 30**
Is resistance less than 0.5 Ω?

YES : Go to step **8L7**.

NO : Replace relay box.

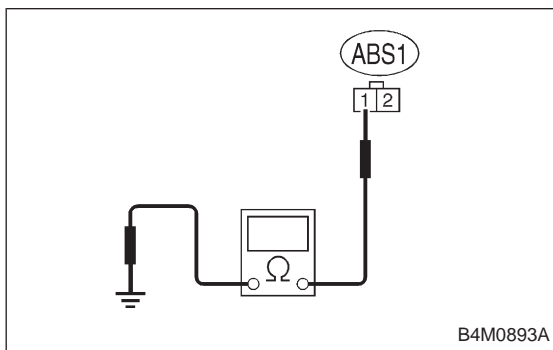
**8L7****CHECK GROUND SHORT IN CONTACT POINT CIRCUIT OF RELAY BOX.**

Measure resistance between hydraulic unit and chassis ground.

CHECK : **Connector & terminal (ABS1) No. 1 — Chassis ground**
Is resistance more than 1 MΩ?

YES : Go to step **8L8**.

NO : Replace relay box. Check fuse No. 19.

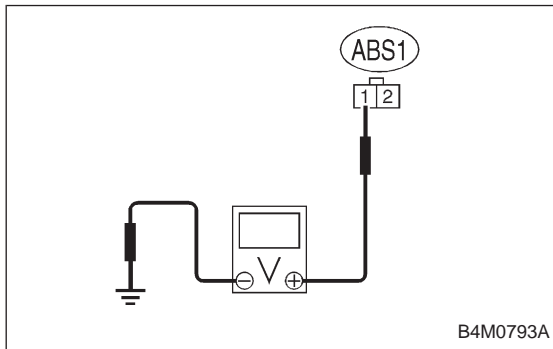
**8L8****CHECK BATTERY SHORT IN CONTACT POINT CIRCUIT OF RELAY BOX.**

- 1) Disconnect connector from ABSCM.
- 2) Turn ignition switch to ON.
- 3) Measure voltage between ABSCM connector and chassis ground.

CHECK : **Connector & terminal (ABS1) No. 1 (+) — Chassis ground (-)**
Is voltage 0 V?

YES : Go to next step.

NO : Replace relay box.

- 4) Turn ignition switch to OFF.

- 5) Measure voltage between ABSCM connector and chassis ground.

CHECK : **Connector & terminal (ABS1) No. 1 (+) — Chassis ground (-)**
Is voltage 0 V?

YES : Go to step **8L9**.

NO : Replace relay box.

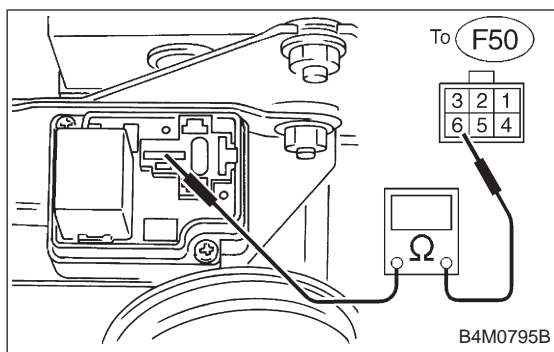
**8L9****CHECK BROKEN WIRE IN MONITOR SYSTEM CIRCUIT OF RELAY BOX.**

- 1) Disconnect connector (F50) from relay box.
- 2) Measure resistance between relay box connector and motor relay installing point.

CHECK : **Connector & terminal**
To (F50) No. 6 — Motor relay installing point
No. 30
Is resistance less than 0.5 Ω?

YES : Go to step **8L10**.

NO : Replace relay box.

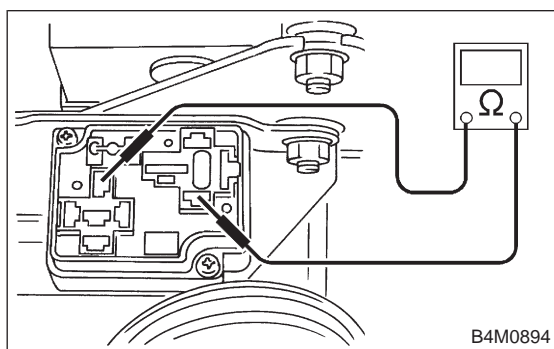
**8L10****CHECK BROKEN WIRE IN CONTROL CIRCUIT OF RELAY BOX.**

- 1) Remove valve relay from relay box.
- 2) Measure resistance between motor relay installing point and valve relay installing point.

CHECK : **Connector & terminal**
Motor relay installing point No. 86 — Valve
relay installing point No. 30
Is resistance less than 0.5 Ω?

YES : Go to next step.

NO : Replace relay box.

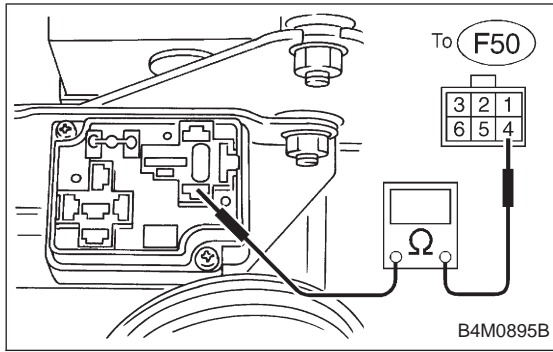

3) Measure resistance between motor relay installing point and relay box connector.

CHECK : **Connector & terminal**
Motor relay installing point No. 86 — To (F50) No. 4
Is resistance less than 0.5 Ω?

YES : Go to step 8L11.

NO : Replace relay box.

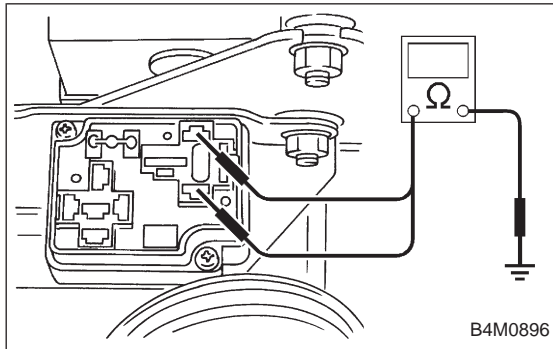

8L11	CHECK GROUND SHORT IN CONTROL CIRCUIT OF RELAY BOX.
-------------	--

Measure resistance between relay box and chassis ground.

CHECK : **Connector & terminal**
Motor relay installing point No. 86 — Chassis ground
Motor relay installing point No. 85 — Chassis ground
Is resistance more than 1 MΩ?

YES : Go to step 8L12.

NO : Replace relay box. Check fuse No. 19.

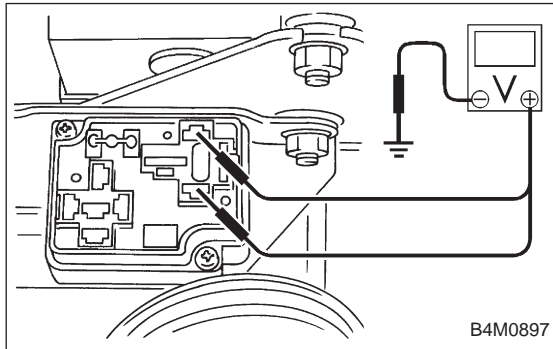

8L12	CHECK BATTERY SHORT IN CONTROL CIRCUIT OF RELAY BOX.
-------------	---

1) Turn ignition switch to ON.
 2) Measure voltage between motor relay installing point and chassis ground.

CHECK : **Connector & terminal**
Motor relay installing point (+) No. 86 — Chassis ground (-)
Motor relay installing point (+) No. 85 — Chassis ground (-)
Is voltage 0 V?

YES : Go to next step.

NO : Replace relay box and check all fuses.

- 3) Turn ignition switch to OFF.
- 4) Measure voltage between motor relay installing point and chassis ground.

CHECK : **Connector & terminal**
Motor relay installing point (+) No. 86 —
Chassis ground
Motor relay installing point (+) No. 85 —
Chassis ground
Is voltage 0 V?

YES : Go to step **8L13**.

NO : Replace relay box and check all fuses.

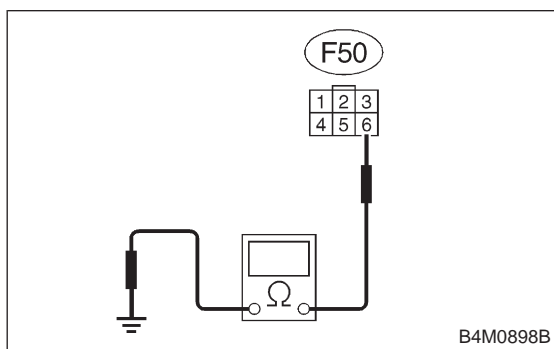
**8L13**
CHECK BROKEN WIRE IN MONITOR SYSTEM HARNESS.

- 1) Connect between terminals No. 10 and No. 1 of ABSCM connector (F49) with a lead wire.
- 2) Measure resistance between relay box connector and chassis ground.

CHECK : **Connector & terminal**
(F50) No. 6 — Chassis ground
Is resistance less than 0.5 Ω?

YES : Go to step **8L14**.

NO : Repair harness connector between ABSCM and relay box.

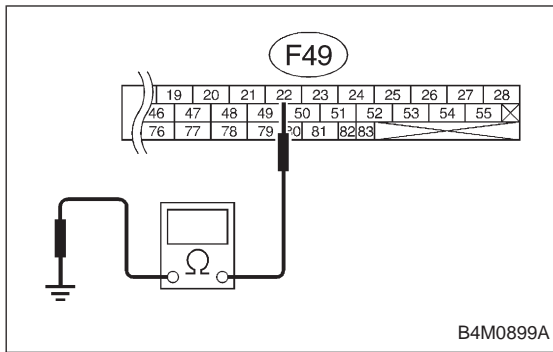

8L14

CHECK BROKEN WIRE IN RELAY CONTROL SYSTEM HARNESS.

- 1) Connect valve relay and motor relay to relay box.
- 2) Connect connector (F50) to relay box.
- 3) Connect connector to hydraulic unit.
- 4) Measure resistance between ABSCM connector and chassis ground.

CHECK : **Connector & terminal (F49) No. 22 — Chassis ground**
Is resistance $80 \pm 10 \Omega$?

YES : Go to step **8L15**.

NO : Repair harness connector between ABSCM and relay box.

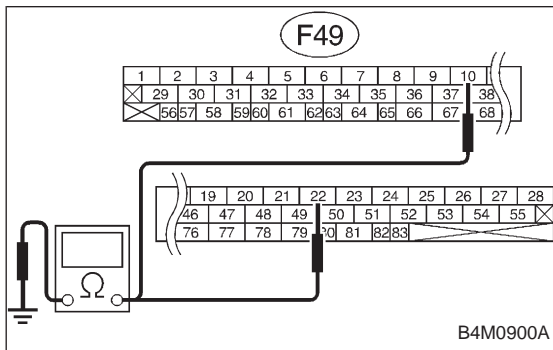

8L15

CHECK GROUND SHORT BETWEEN RELAY BOX AND ABSCM.

- 1) Disconnect connector (F50) from relay box.
- 2) Measure resistance between ABSCM connector and chassis ground.

CHECK : **Connector & terminal (F49) No. 22 — Chassis ground**
(F49) No. 10 — Chassis ground
Is resistance more than $1 M\Omega$?

YES : Go to step **8L16**.

NO : Repair harness between ABSCM and relay box. Check fuse No. 19 and SBF6.

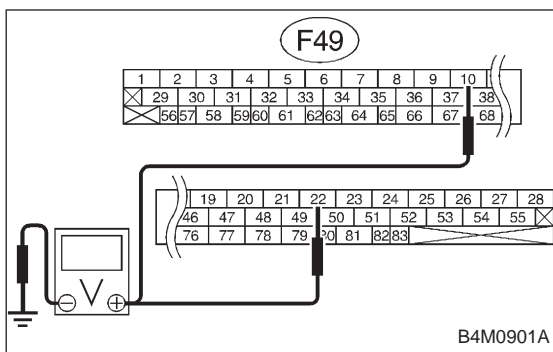

8L16 CHECK BATTERY SHORT BETWEEN RELAY BOX AND ABSCM.

- 1) Turn ignition switch to ON.
- 2) Measure voltage between ABSCM and chassis ground.

CHECK : **Connector & terminal**
(F49) No. 22 (+) — Chassis ground (-)
(F49) No. 10 (+) — Chassis ground (-)
Is voltage 0 V?

- YES** : Go to next step.
NO : Repair harness between relay box and ABSCM.
 Check fuse SBF6.

- 3) Turn ignition switch to OFF.
- 4) Measure voltage between ABSCM and chassis ground.

CHECK : **Connector & terminal**
(F49) No. 22 (+) — Chassis ground (-)
(F49) No. 10 (+) — Chassis ground (-)
Is voltage 0 V?

- YES** : Go to step 8L17.
NO : Repair harness between relay box and ABSCM.
 Check fuse SBF6.

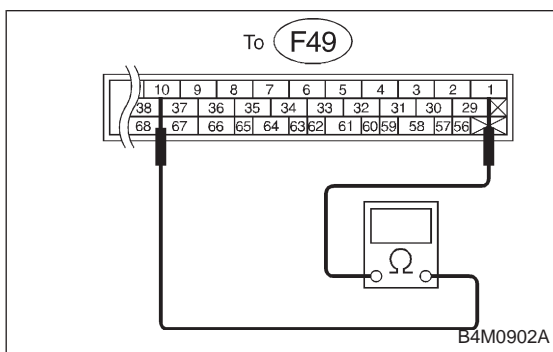

8L17 CHECK GROUND SHORT AT ABSCM MONITOR TERMINAL.

Measure resistance between ABSCM terminals.

CHECK : **Connector & terminal**
To (F49) No. 10 — No. 1
Is resistance less than 0.5 Ω?

- YES** : Go to step 8L18.
NO : Replace ABSCM.

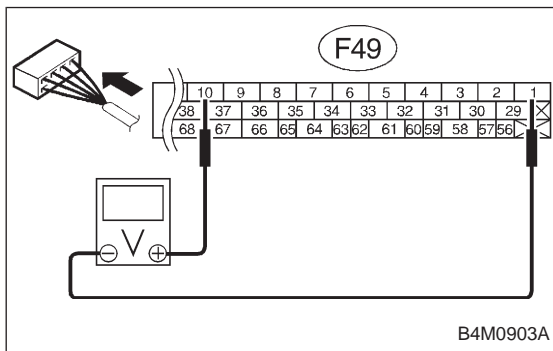

8L18 CHECK BATTERY SHORT AT ABSCM MONITOR TERMINAL.

- 1) Disconnect connector cover from ABSCM connector.
 <Ref. to 4-4c [T8C1] steps 5) to 8).>
- 2) Connect all connectors.
- 3) Turn ignition switch to ON.
- 4) Measure voltage between ABSCM connector terminals.

CHECK : **Connector & terminal**
(F49) No. 10 (+) — No. 1 (-)
Is voltage less than 2 V?

- YES** : Go to next step.
NO : Replace ABSCM.

- 5) Turn ignition switch to OFF.
- 6) Measure voltage between ABSCM connector terminals.

CHECK : **Connector & terminal**
(F49) No. 10 (+) — No. 1 (-)
Is voltage less than 2 V?

- YES** : Go to step 8L19.
NO : Replace ABSCM.

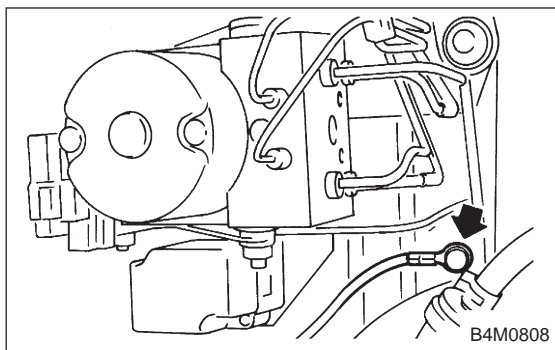

8L19 CHECK MOTOR GROUND.

- CHECK** : *Tightening torque:*
32±10 N·m (3.3±1.0 kg-m, 24±7 ft-lb)
Is the motor ground terminal tightly clamped?
- YES** : Go to step **8L20**.
- NO** : Tighten the clamp of motor ground terminal.

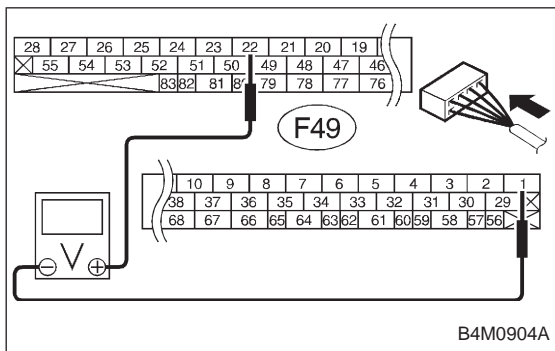

8L20 CHECK ABSCM MOTOR DRIVE TERMINAL.

- 1) Measure voltage between ABSCM connector terminals.
 - 2) Operate the check sequence. <Ref. to 4-4 [W22D1].>
- CHECK** : *Connector & terminal*
(F49) No. 22 (+) — No. 1 (-)
Does the voltage drop from 10 — 13 V to less than 1.5 V, and rise to 10 — 13 V again when carrying out the check sequence?
- YES** : Go to step **8L21**.
- NO** : Replace ABSCM.

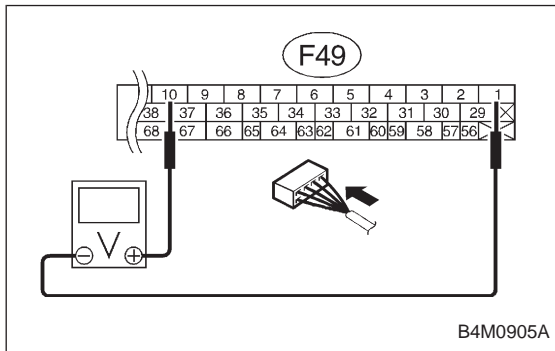

8L21 CHECK MOTOR OPERATION.

- 1) Measure voltage between ABSCM connector terminals.
 - 2) Operate the check sequence. <Ref. to 4-4 [W22D1].>
- CHECK** : *Connector & terminal*
(F49) No. 10 (+) — No. 1 (-)
Does the voltage raise from less than 1.5 V to 10 — 13 V, and return to less than 1.5 V again when carrying out the check sequence?
Can motor revolution noise (buzz) be heard when carrying out the check sequence?
- YES** : Go to step **8L22**.
- NO** : Replace hydraulic unit.

8L22	CHECK POOR CONTACT IN CONNECTOR BETWEEN HYDRAULIC UNIT, RELAY BOX AND ABSCM.
-------------	---

CHECK : *Is there poor contact in connector between hydraulic unit, relay box and ABSCM?*

YES : Repair connector.

NO : Go to step **8L23**.

8L23	CHECK ABSCM.
-------------	---------------------

- 1) Connect all connectors.
- 2) Erase the memory.
- 3) Perform inspection mode.
- 4) Read out the trouble code.

CHECK : *Is the same trouble code as in the current diagnosis still being output?*

YES : Replace ABSCM.

NO : Go to next **CHECK** .

CHECK : *Are other trouble codes being output?*

YES : Proceed with the diagnosis corresponding to the trouble code.

NO : A temporary poor contact.

**M: TROUBLE CODE 54
— ABNORMAL STOP LIGHT SWITCH —****DIAGNOSIS:**

- Faulty stop light switch

TROUBLE SYMPTOM:

- ABS does not operate.

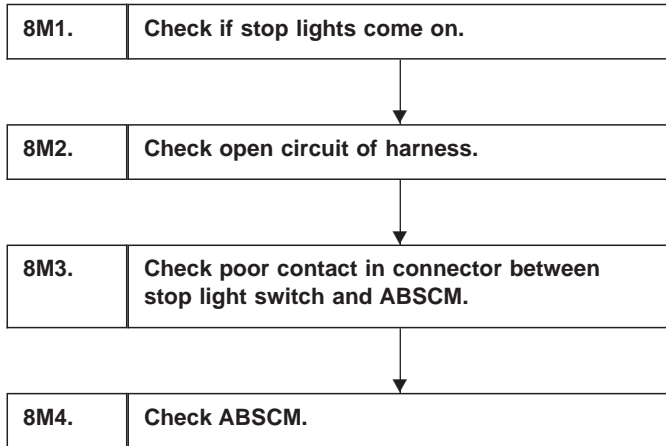

WIRING DIAGRAM:

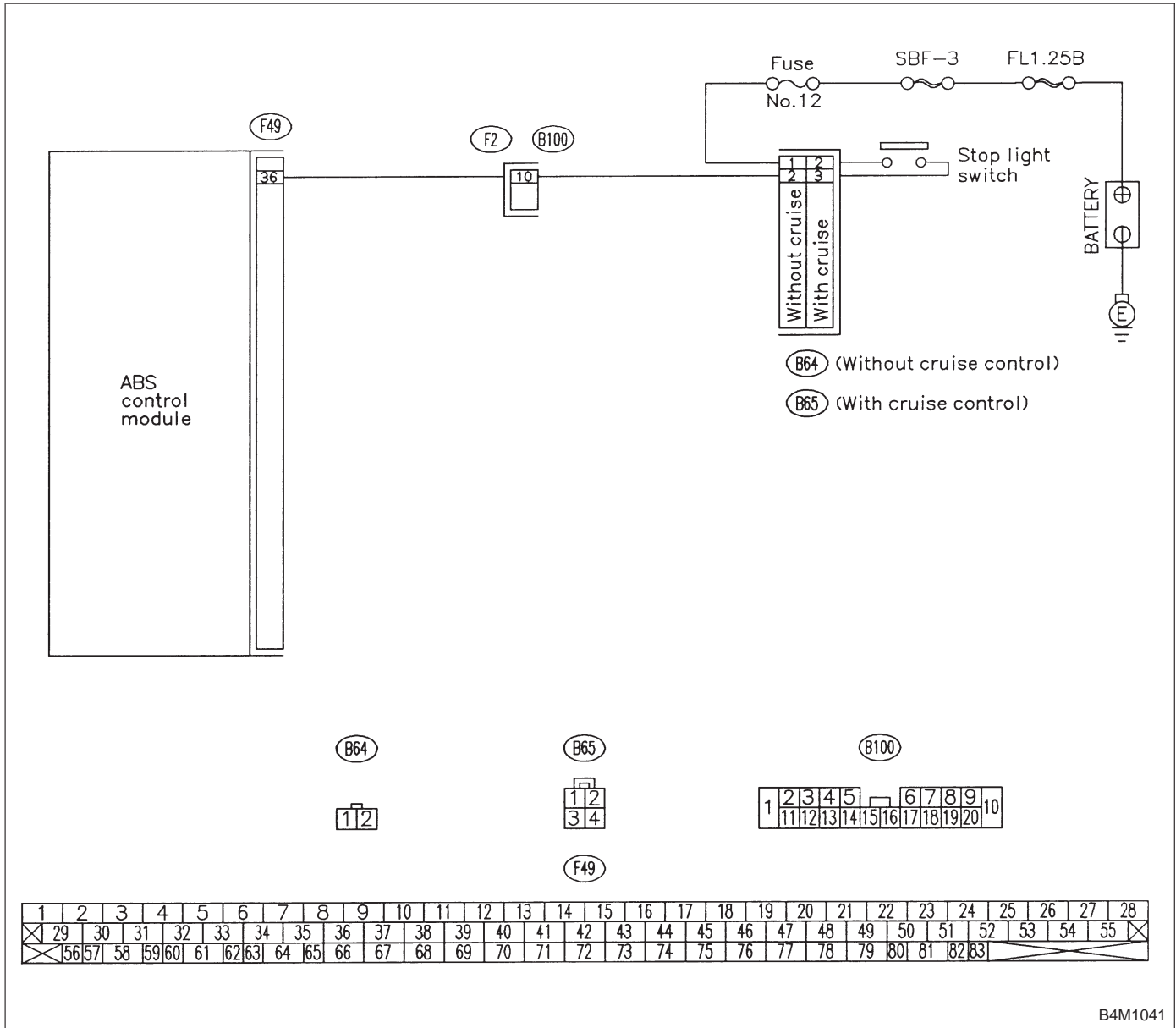

B4M1041

8M1	CHECK IF STOP LIGHTS COME ON.
------------	--------------------------------------

Depress the brake pedal.

CHECK : *Do stop lights turn on?*

YES : Go to step **8M2**.

NO : Repair stop lights circuit.

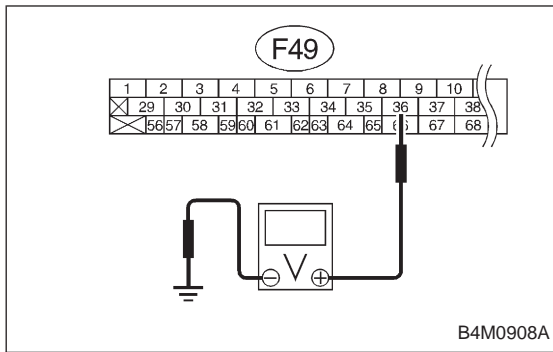

8M2 CHECK OPEN CIRCUIT OF HARNESS.

- 1) Turn ignition switch to OFF.
- 2) Disconnect connector from ABSCM.
- 3) Depress brake pedal.
- 4) Measure voltage between ABSCM connector and chassis ground.

CHECK : *Connector & terminal (F49) No. 36 — Chassis ground
Is voltage 10 — 13 V?*

YES : Go to step **8M3**.

NO : Repair harness between stop light switch and ABSCM.

8M3 CHECK POOR CONTACT IN CONNECTOR BETWEEN STOP LIGHT SWITCH AND ABSCM.

CHECK : *Is there poor contact in connector between stop light switch and ABSCM?*

YES : Repair connector.

NO : Go to step **8M4**.

8M4 CHECK ABSCM.

- 1) Connect all connectors.
- 2) Erase the memory.
- 3) Perform inspection mode.
- 4) Read out the trouble code.

CHECK : *Is the same trouble code as in the current diagnosis still being output?*

YES : Replace ABSCM.

NO : Go to next **CHECK** .

CHECK : *Are other trouble codes being output?*

YES : Proceed with the diagnosis corresponding to the trouble code.

NO : A temporary poor contact.

**N: TROUBLE CODE 56
— ABNORMAL G SENSOR OUTPUT
VOLTAGE —****DIAGNOSIS:**

- Faulty G sensor output voltage

TROUBLE SYMPTOM:

- ABS does not operate.

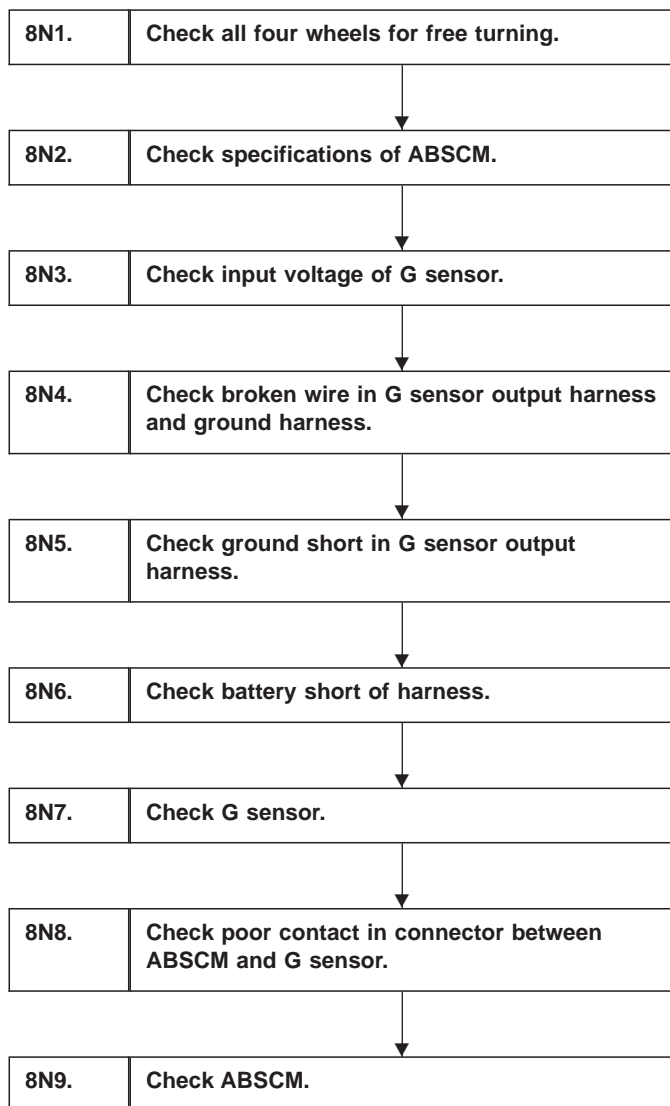

WIRING DIAGRAM:

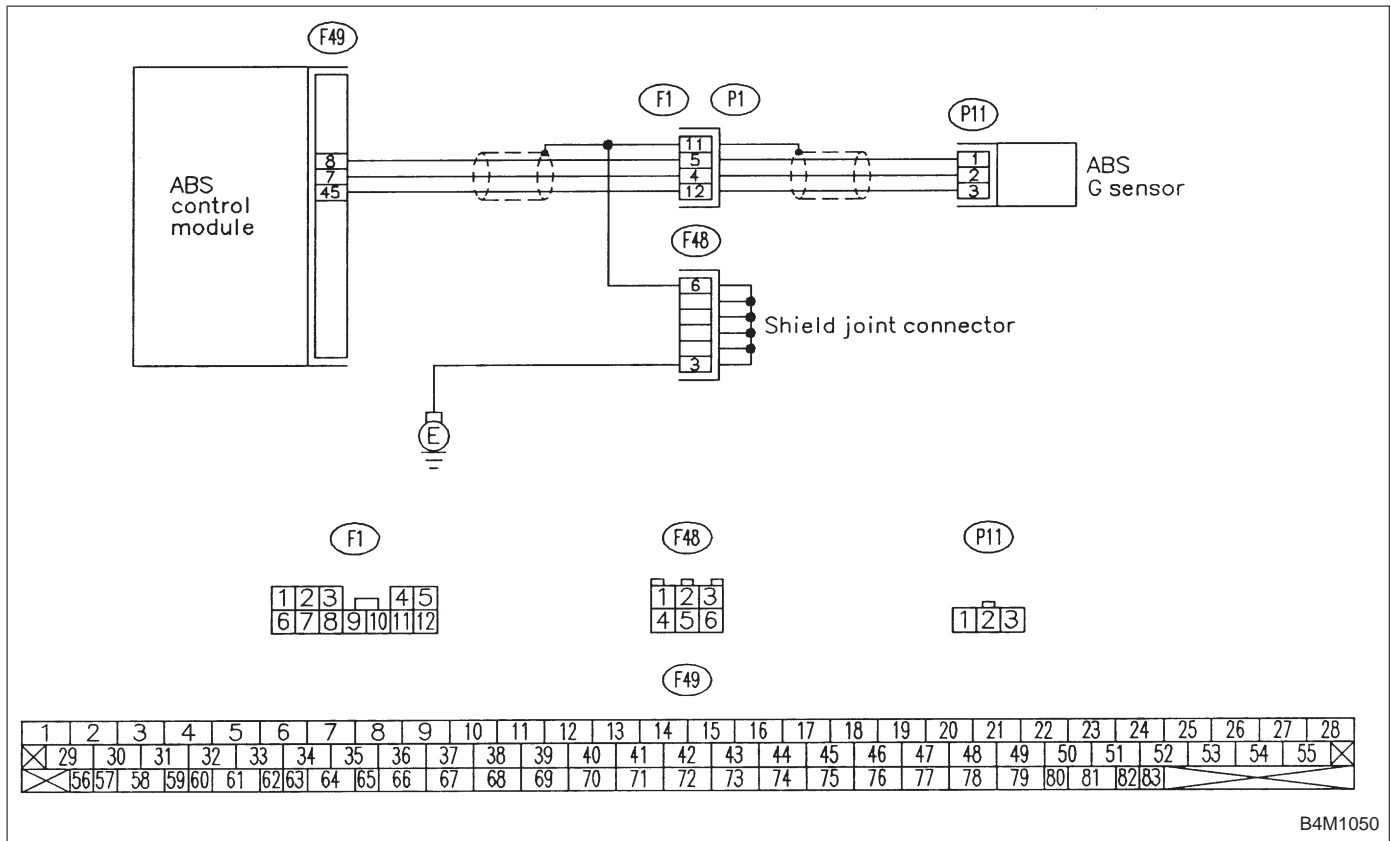

8N1 **CHECK ALL FOUR WHEELS FOR FREE TURNING.**

- CHECK** : Have the wheels been turned freely such as when the vehicle is lifted up, or operated on a rolling road?
- YES** : The ABS is normal. Erase the trouble code.
- NO** : Go to step 8N2.

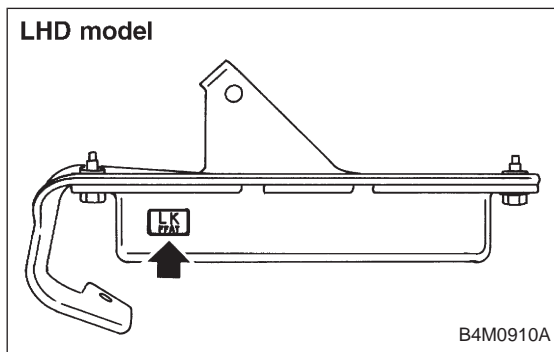

8N2 **CHECK SPECIFICATIONS OF ABSCM.**

Check specifications of the plate attached to the ABSCM.

CHECK : Is an ABSCM for 4WD model installed on a FWD model?

CAUTION:
Be sure to turn ignition switch to OFF when removing ABSCM.

- YES** : Replace ABSCM.
- NO** : Go to step 8N3.

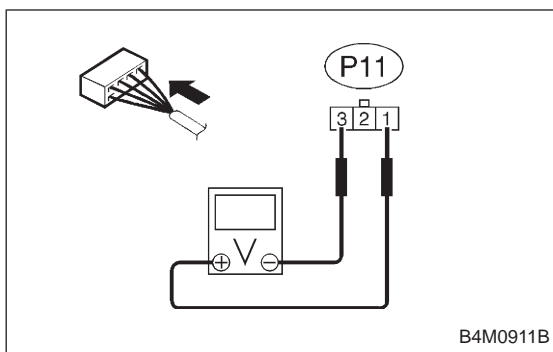

8N3 CHECK INPUT VOLTAGE OF G SENSOR.

- 1) Turn ignition switch to OFF.
- 2) Remove console box.
- 3) Disconnect G sensor from body. (Do not disconnect connector.)
- 4) Turn ignition switch to ON.
- 5) Measure voltage between G sensor connector terminals.

CHECK : **Connector & terminal (P11) No. 1 (+) — No. 3 (-)**
Is voltage 5 ± 0.25 V?

YES : Go to step 8N4.

NO : Repair harness connector between G sensor and ABSCM.

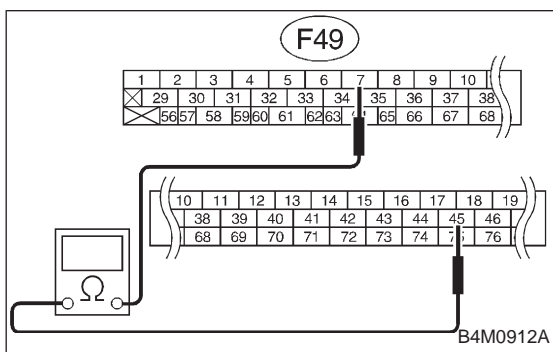

8N4 CHECK BROKEN WIRE IN G SENSOR OUTPUT HARNESS AND GROUND HARNESS.

- 1) Turn ignition switch to OFF.
- 2) Disconnect connector from ABSCM.
- 3) Measure resistance between ABSCM connector terminals.

CHECK : **Connector & terminal (F49) No. 7 — No. 45**
Is resistance 4.6 ± 0.3 kΩ?

YES : Go to step 8N5.

NO : Repair harness between G sensor and ABSCM.

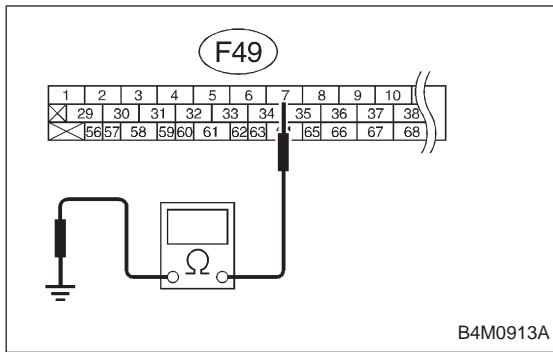

8N5 **CHECK GROUND SHORT IN G SENSOR OUTPUT HARNESS.**

- 1) Disconnect connector from G sensor.
- 2) Measure resistance between ABSCM connector and chassis ground.

CHECK : **Connector & terminal (F49) No. 7 — Chassis ground**
Is resistance more than 1 MΩ?

YES : Go to step **8N6**.

NO : Repair harness between G sensor and ABSCM.

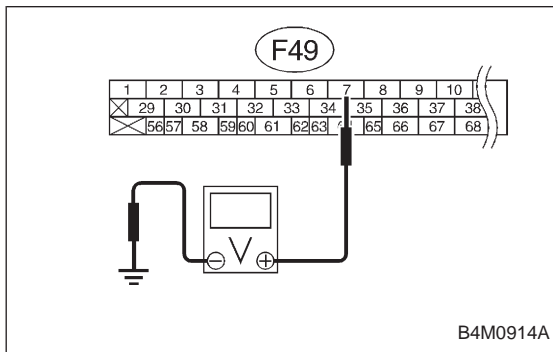

8N6 **CHECK BATTERY SHORT OF HARNESS.**

- 1) Turn ignition switch to ON.
- 2) Measure voltage between ABSCM connector and chassis ground.

CHECK : **Connector & terminal (F49) No. 7 (+) — Chassis ground (-)**
Is voltage 0 V?

YES : Go to next step.

NO : Repair harness between G sensor and ABSCM.

- 3) Turn ignition switch to OFF.
- 4) Measure voltage between ABSCM connector and chassis ground.

CHECK : **Connector & terminal (F49) No. 7 (+) — Chassis ground (-)**
Is voltage 0 V?

YES : Go to step **8N7**.

NO : Repair harness between G sensor and ABSCM.

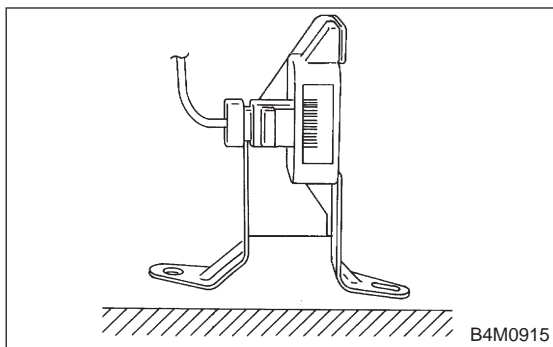
**8N7****CHECK G SENSOR.**

- 1) Remove G sensor from vehicle.
- 2) Connect connector to G sensor.
- 3) Connect connector to ABSCM.
- 4) Turn ignition switch to ON.
- 5) Measure voltage between G sensor connector terminals.

CHECK : **Connector & terminal (P11) No. 2 (+) — No. 1 (-)**
Is voltage 2.3 ± 0.2 V when G sensor is horizontal?

YES : Go to next **CHECK** .

NO : Replace G sensor.

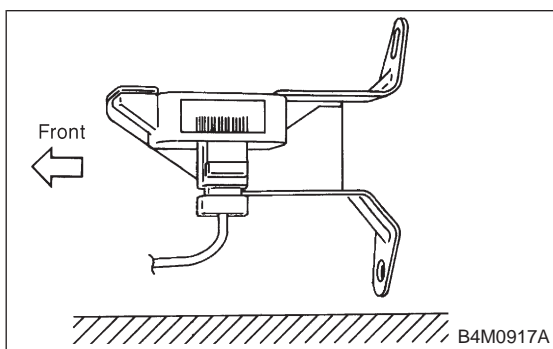

CHECK : **Connector & terminal (P11) No. 2 (+) — No. 1 (-)**
Is voltage 3.9 ± 0.2 V when G sensor is inclined forwards to 90°?

YES : Go to next **CHECK** .

NO : Replace G sensor.

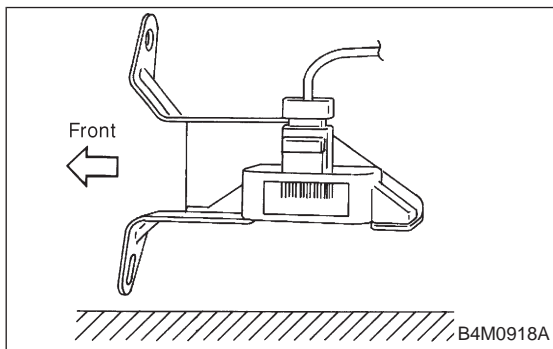

CHECK : **Connector & terminal (P11) No. 2 (+) — No. 1 (-)**
Is voltage 0.7 ± 0.2 V when G sensor is inclined backwards to 90°?

YES : Go to step **8N8**.

NO : Replace G sensor.

8N8**CHECK POOR CONTACT IN CONNECTOR BETWEEN ABSCM AND G SENSOR.**

CHECK : **Is there poor contact in connector between ABSCM and G sensor?**

YES : Repair connector.

NO : Go to step **8N9**.

8N9	CHECK ABSCM.
------------	---------------------

- 1) Connect all connectors.
- 2) Erase the memory.
- 3) Perform inspection mode.
- 4) Read out the trouble code.

CHECK : *Is the same trouble code as in the current diagnosis still being output?*

YES : Replace ABSCM.

NO : Go to next **CHECK** .

CHECK : *Are other trouble codes being output?*

YES : Proceed with the diagnosis corresponding to the trouble code.

NO : A temporary poor contact.